

FICHA TÉCNICA / FICHE TECHNIQUE / TECHNICAL SHEET

SERIE 118

SERIE 118



SERIE 118 P



SERIE 118

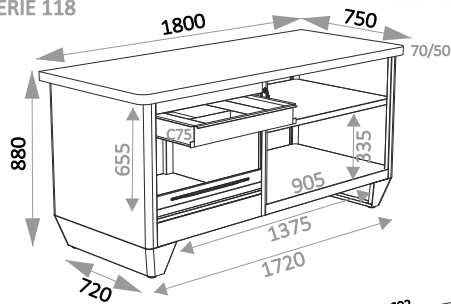

SERIE 118 C

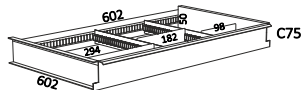

i ESTANTERIA FIJA
ÉTAGÈRE FIXE
FIXED SHELF

SERIE 118 P

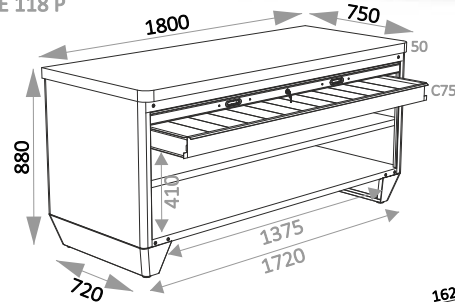

SERIE 118 18 C

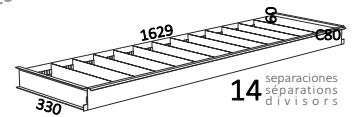

i ESTANTERIA REGULABLE
ÉTAGÈRE RÉGLABLE
AMOVIBLE SHELF

14 separaciones
séparations
divisors

Componentes / Composants / Components

Material Matériel Material



Estructura y cajón. Châssis and tiroir. Frame and drawer.	Chapa pulida / Soldado resistencia Tôle polie / Résistance soudée Polished sheet / Welded resistance	1,5 mm
Interiores. Intérieurs. Interiors.	Chapa pulida Tôle polie Polished sheet	1,2 mm
Encimera. Plan de travail. Worktop.	Chapa pulida Tôle polie Polished sheet	3 mm
Lamas persiana. Stores à lamelles. Slats shutters.	Chapa pulida Tôle polie Polished sheet	0,6 mm
Pata ajustable. Pied réglable. Adjustable leg.	Inferior polipropileno negro. Fond polypropylène noir. Bottom black polypropylene.	Rosca metal cromado Filetage métal chromé Thread chrome-plated metal
Color Couleur Colour	Azul martelé Bleu martelé Hammered blue	Color opcional Couleur sur demande Choice of colours

Acabado Finition / Finishing

Soldado por resistencia, secado a estufa, previo desengrasado y fosfatado.
Soudée par résistance, séchée au four après dégraissage et phosphatage.
Welded by resistance, drying oven prior degreasing and phosphate.

Características

Caractéristiques / Characteristics

118	i	Monobloque totalmente soldado. Monobloc totalement soudé. Welded monobloc.
118 P	i	Monobloque soldado y atornillado. Monobloc soudé et vissé. Totally welded and screwed monobloc.
1000	KG	Carga total repartida, admitida. Charge totale répartie, admise. Total load distributed, admitted.
D	M	DM-Chapa-Madera castaño MDF-Tôle-Bois châtaignier MDF-Metal-Chesnut wood
e		50-70 mm
		Incluye pies regulables para la nivelación. Comprend des pieds réglables pour la mise à niveau. Includes adjustable feet for leveling.
		Cierre centralizado con llave (2 llaves). Fermeture centralisée à clé (2 clés). Centralized closing and handle lock (2 keys).
		Cartón individual y palet. Carton simple et palette. Single cardboard and pallet.

SERIES / SÉRIES / SERIES

	e	Encimera Plan de travail Worktop		Cajón Tiroir Drawer	DIMENSIONES PRODUCTO DIMENSIONS PRODUIT PRODUCT DIMENSIONS	DIMENSIONES EMBALAJE DIMENSIONS EMBALLAGE PACKAGING DIMENSIONS			PESO POIDS WEIGHT			
		70 mm	50 mm			forma superior forme supérieure higher form	GS	100		GT	100	KG
SERIE 118	118	70 mm			1800 mm	750 mm	880 mm	880 mm	800 mm	1930 mm	142	
	118 D		50 mm								118 C	141
	118 M		50 mm								144	
SERIE 118 P	118 18 P	50 mm			1800 mm	750 mm	880 mm	880 mm	800 mm	1930 mm	142	
	118 18 PD		50 mm								118 18 C	141
	118 18 PM		50 mm								144	