

FICHA TÉCNICA / FICHE TECHNIQUE / TECHNICAL SHEET

SERIE 112 PM

B



SERIE 112 15 C PM 30 B

H min. 610 mm.
H max. 910 mm.

OPCIÓN: Ruedas.
OPTION: Roues.
OPTION: Wheels.



SERIE 112 15 D PM 30 B R

H min. 716 mm.
H max. 1016 mm.

S



SERIE 112 15 M PM 30 S

H min. 750 mm.
H max. 1050 mm.

Options

Encimeras
Plan de travail
Woktop

Materiales
Matériaux
Materials



C



M



D

ENCIMERAS / PLAN DE TRAVAIL / WORKTOP		
L	1000 / 1300 / 1500 / 1800 / 2000	
	C	D M
	50 mm	
B	610	910
S	750	1050
A	880	1180
	H min (mm)	H max (mm)

A



SERIE 112 15 D PM 30 A

H min. 880 mm.
H max. 1180 mm.

Ref. 112 PM-PH R

Juego de ruedas giratorias (2 con freno). Recubrimiento de goma.
Jeu de roulettes pivotantes (2 avec freins). Revêtement en caoutchouc.
Set of swivel castors (2 with brakes). Rubber coating.



H 106 mm Ø 80 mm



FICHA TÉCNICA / FICHE TECHNIQUE / TECHNICAL SHEET

SERIE 112 PM

	L	L ₁
SERIE 112 10	1000	627
SERIE 112 13	1300	957
SERIE 112 15	1500	1177
SERIE 112 18	1800	1507
SERIE 112 20	2000	1617

B H min. 610 mm.
H max. 910 mm.

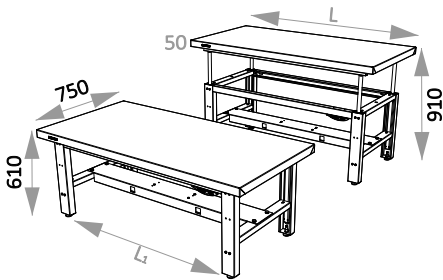

S H min. 750 mm.
H max. 1050 mm.

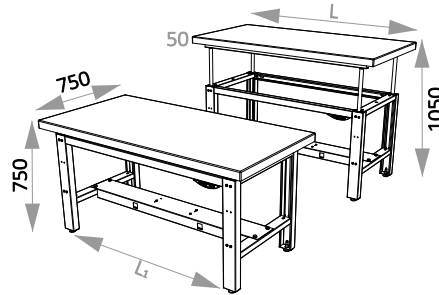

A H min. 880 mm.
H max. 1180 mm.

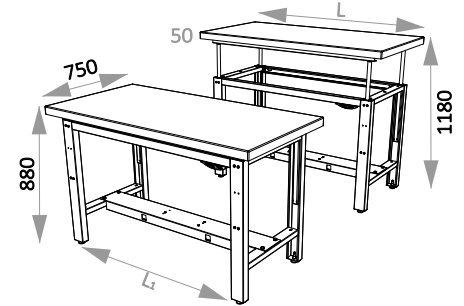

Características
Caractéristiques / Characteristics



Se entrega MONTADO.
Livraison ASSEMBLÉE.
Supplied SUPLIED.



Carga total repartida, admitida.
Charge totale répartie, admise.
Total load distributed, admitted.



Chapa-DM-Madera castaño
Tôle-MDF-Bois châtaigner
Metal-MDF-Chesnut wood



50 mm

Componentes
Composants / Components

Material Matériel Material



Estructura.
Châssis.
Frame.

Chapa pulida
Tôle polie
Polished sheet

2 mm

Mecanismo.
Mécanisme.
Mechanism.

Eléctrico (Panel de control)
Électrique (Panneau de contrôle)
Electric (Control panel)

Recorrido
Élévation
Elevation.

300 mm

Color
Couleur
Colour

Azul martelé
Bleu martelé
Hammered blue

Color opcional
Couleur sur demande
Choice of colours

Acabado Finition / Finishing

Soldado por resistencia, secado a estufa, previo desengrasado y fosfatado.
Soudée par résistance, séchée au four après dégraissage et phosphatage.
Welded by resistance, drying oven prior degreasing and phosphate.

Ruedas.
Roues.
Wheels.

4 giratorias (2 con freno).
4 pivotantes (2 avec frein).
4 swivel wheels (2 with brake).

Recubrimiento en goma.
Revêtement en caoutchouc.
Rubber coating.



Ø 80mm
H 106mm

Incluye pies regulables para facilitar el nivel en la instalación.
Il comprend des pieds réglables pour faciliter le niveau dans l'installation.
It includes adjustable feet to facilitate the level in the installation.

SERIES / SÉRIES / SERIES

	P E S O POIDS WEIGHT	Encimera Plan de travail Worktop			mm
		KG			
B	1000				1040 x 800 x 710
	112 10 C PM 30 B	38.68	•		
	112 10 D PM 30 B	42.55		•	
	112 10 M PM 30 B	40.38			•
	1300				1340 x 800 x 710
	112 13 C PM 30 B	49.29	•		
	112 13 D PM 30 B	52.73		•	
	112 13 M PM 30 B	51.06			•
	1500				1540 x 800 x 710
112 15 C PM 30 B	56.73	•			
112 15 D PM 30 B	61.87		•		
112 15 M PM 30 B	58.62			•	
1800				1840 x 800 x 710	
112 18 C PM 30 B	66.37	•			
112 18 D PM 30 B	73.09		•		
112 18 M PM 30 B	68.99			•	
2000				2040 x 800 x 710	
112 20 C PM 30 B	74.16	•			
112 20 D PM 30 B	80.89		•		
112 20 M PM 30 B	76.40			•	
S	1000				1040 x 800 x 880
	112 10 C PM 30 S	50.04	•		
	112 10 D PM 30 S	55.04		•	
	112 10 M PM 30 S	52.24			•
	1300				1340 x 800 x 880
	112 13 C PM 30 S	63.76	•		
	112 13 D PM 30 S	68.22		•	
	112 13 M PM 30 S	66.06			•
	1500				1540 x 800 x 880
112 15 C PM 30 S	73.39	•			
112 15 D PM 30 S	80.04		•		
112 15 M PM 30 S	75.84			•	
1800				1840 x 800 x 880	
112 18 C PM 30 S	85.86	•			
112 18 D PM 30 S	94.56		•		
112 18 M PM 30 S	89.26			•	
2000				2040 x 800 x 880	
112 20 C PM 30 S	95.94	•			
112 20 D PM 30 S	104.64		•		
112 20 M PM 30 S	98.84			•	
A	1000				1040 x 800 x 1010
	112 10 C PM 30 A	52.48	•		
	112 10 D PM 30 A	57.48		•	
	112 10 M PM 30 A	54.68			•
	1300				1340 x 800 x 1010
	112 13 C PM 30 A	66.93	•		
	112 13 D PM 30 A	71.39		•	
	112 13 M PM 30 A	69.23			•
	1500				1540 x 800 x 1010
	112 15 C PM 30 A	77.05	•		
	112 15 D PM 30 A	83.70		•	
	112 15 M PM 30 A	79.50			•
	1800				1840 x 800 x 1010
	112 18 C PM 30 A	90.25	•		
	112 18 D PM 30 A	98.95		•	
	112 18 M PM 30 A	93.65			•
	2000				2040 x 800 x 1010
	112 20 C PM 30 A	100.82	•		
112 20 D PM 30 A	109.52		•		
112 20 M PM 30 A	103.72			•	



Cartón individual y palet.
Carton simple et palette.
Single cardboard and pallet.