

FICHA TÉCNICA / FICHE TECHNIQUE / TECHNICAL SHEET

SERIE 112 PM

B



SERIE 112 15 C PM 30 B

H min. 580 mm.
H max. 880 mm.

OPCIÓN: Ruedas.
OPTION: Roues.
OPTION: Wheels.



SERIE 112 15 D PM 30 B R

H min. 686 mm.
H max. 986 mm.

S



SERIE 112 15 M PM 30 S

H min. 750 mm.
H max. 1050 mm.



SERIE 112 15 K PM 30 S

H min. 710 mm.
H max. 1010 mm.

A



SERIE 112 15 D PM 30 A

H min. 880 mm.
H max. 1180 mm.

Options

Materiales encimera
Matériaux du plan de travail
Worktop materials



	ENCIMERAS / PLAN DE TRAVAIL / WORKTOP			
	L 1000 / 1300 / 1500 / 1800 / 2000			
	C	D	M	K
	50 mm		12 mm	
B	580	880	542	842
S	750	1050	712	1012
A	880	1180	842	1142
	H min (mm)	H max (mm)	H min (mm)	H max (mm)

FICHA TÉCNICA / FICHE TECHNIQUE / TECHNICAL SHEET

SERIE 112 PM

	L	L ₁
SERIE 112 10	1000	627
SERIE 112 13	1300	957
SERIE 112 15	1500	1177
SERIE 112 18	1800	1507
SERIE 112 20	2000	1617

B H min. 580 mm.
H max. 880 mm.

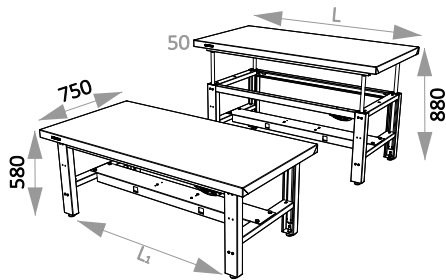

S H min. 750 mm.
H max. 1050 mm.

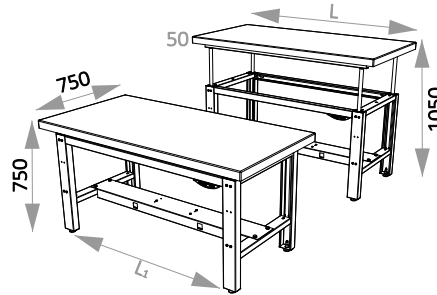

A H min. 880 mm.
H max. 1180 mm.

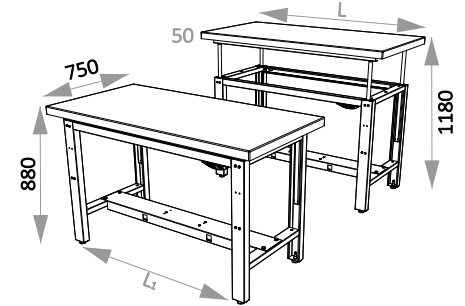

Características
Caractéristiques / Characteristics



Se entrega MONTADO.
Livraison ASSEMBLÉE.
Supplied SUPLIED.



Carga total repartida, admitida.
Charge totale répartie, admise.
Total load distributed, admitted.



Chapa-DM-Madera castaño
Tôle-MDF-Bois châtaigner
Metal-MDF-Chesnut wood

50 mm



Encimera Compacto (CDF)
Plan de Kompact (CDF)
Worktop Kompact (CDF)

12 mm

Componentes
Composants / Components

Material Matériel Material



Estructura .
Châssis.
Frame .

Chapa pulida
Tôle polie
Polished sheet

2 mm

Mecanismo.
Mécanisme.
Mechanism.

Eléctrico (Panel de control)
Électrique (Panneau de contrôle)
Electric (Control panel)

Recorrido
Élévation
Elevation.

300 mm

Color
Couleur
Colour

Azul martelé
Bleu martelé
Hammered blue

Color opcional
Couleur sur demande
Choice of colours

Acabado Finition / Finishing

Soldado por resistencia, secado a estufa, previo desengrasado y fosfatado.
Soudée par resistance, séchée au four après dégraissage et phosphatage.
Welded by resistance, drying oven prior degreasing and phosphate.

Ruedas.
Roues.
Wheels.

4 giratorias (2 con freno).
4 pivotantes (2 avec frein).
4 swivel wheels (2 with brake).

Recubrimiento en goma.
Revêtement en caoutchouc.
Rubber coating.

Ø 80mm
H 106mm



Incluye pies regulables para facilitar el nivel en la instalación.
Il comprend des pieds réglables pour faciliter le niveau dans l'installation.
It includes adjustable feet to facilitate the level in the installation.

SERIES / SÉRIES / SERIES

	PESO POIDS WEIGHT	Encimera Plan de travail Worktop				mm
B	112 10 C PM 30 B	38.68	•			1040 x 800 x 710
	112 10 D PM 30 B	42.55		•		
	112 10 M PM 30 B	40.38			•	
	112 10 K PM 30 B	30.09			•	1040 x 800 x 675
	112 13 C PM 30 B	49.29	•			
	112 13 D PM 30 B	52.73		•		
	112 13 M PM 30 B	51.06			•	1340 x 800 x 710
	112 13 K PM 30 B	38.00			•	
	112 15 C PM 30 B	56.73	•			
	112 15 D PM 30 B	61.87		•		1540 x 800 x 710
	112 15 M PM 30 B	58.62			•	
	112 15 K PM 30 B	43.39			•	
112 18 C PM 30 B	66.37	•			1540 x 800 x 675	
112 18 D PM 30 B	73.09		•			
112 18 M PM 30 B	68.99			•		
112 18 K PM 30 B	50.91			•	1840 x 800 x 710	
112 20 C PM 30 B	74.16	•				
112 20 D PM 30 B	80.89		•			
112 20 M PM 30 B	76.40			•	2040 x 800 x 710	
112 20 K PM 30 B	56.31			•		
112 10 C PM 30 S	50.04	•				1040 x 800 x 880
112 10 D PM 30 S	55.04		•			
112 10 M PM 30 S	52.24			•		
112 10 K PM 30 S	38.92			•	1040 x 800 x 845	
112 13 C PM 30 S	63.76	•				
112 13 D PM 30 S	68.22		•			
112 13 M PM 30 S	66.06			•	1340 x 800 x 880	
112 13 K PM 30 S	49.16			•		
112 15 C PM 30 S	73.39	•				
112 15 D PM 30 S	80.04		•		1540 x 800 x 880	
112 15 M PM 30 S	75.84			•		
112 15 K PM 30 S	56.14			•		
112 18 C PM 30 S	85.86	•			1540 x 800 x 845	
112 18 D PM 30 S	94.56		•			
112 18 M PM 30 S	89.26			•		
112 18 K PM 30 S	65.86			•	1840 x 800 x 880	
112 20 C PM 30 S	95.94	•				
112 20 D PM 30 S	104.64		•			
112 20 M PM 30 S	98.84			•	2040 x 800 x 880	
112 20 K PM 30 S	72.84			•		
112 10 C PM 30 A	52.48	•				1040 x 800 x 1010
112 10 D PM 30 A	57.48		•			
112 10 M PM 30 A	54.68			•		
112 10 K PM 30 A	41.38			•	1040 x 800 x 975	
112 13 C PM 30 A	66.93	•				
112 13 D PM 30 A	71.39		•			
112 13 M PM 30 A	69.23			•	1340 x 800 x 1010	
112 13 K PM 30 A	52.33			•		
112 15 C PM 30 A	77.05	•				
112 15 D PM 30 A	83.70		•		1540 x 800 x 1010	
112 15 M PM 30 A	79.50			•		
112 15 K PM 30 A	59.80			•		
112 18 C PM 30 A	90.25	•			1540 x 800 x 975	
112 18 D PM 30 A	98.95		•			
112 18 M PM 30 A	93.65			•		
112 18 K PM 30 A	70.25			•	1840 x 800 x 1010	
112 20 C PM 30 A	100.82	•				
112 20 D PM 30 A	109.52		•			
112 20 M PM 30 A	103.72			•	2040 x 800 x 1010	
112 20 K PM 30 A	77.72			•		
112 20 K PM 30 A	77.72			•		2040 x 800 x 975

Cartón individual y palet.
Carton simple et palette.
Single cardboard and pallet.