

SERIE 111



SERIE 112  
1000-1300-1500-1800-2000



SERIE 118

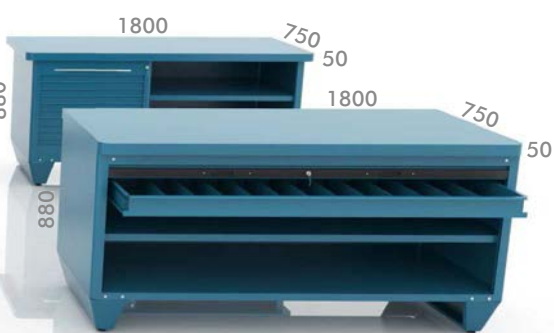

1000-1300-1500-1800-2000  
SERIE 150 + 110



1000-1300-1500-1800-2000  
SERIE 150



1500-1800-2000  
SERIE 142

**ACCESORIOS**  
ACCESSOIRES  
ACCESSORIES

**CAJONES**  
TIROIRS  
DRAWERS



Ref. 132



SERIE 113



Ref. 129



Ref. 133



SERIE 153

**RUEDAS**  
ROUES  
WHEELS



Ø= 150 mm  
H= 188 mm

Recubrimiento poliuretano.  
Recouvrement polyuréthane.  
Polyuretane covering.



Ø 100mm  
H 135mm

Ruedas de goma.  
Roues en caoutchouc.  
Rubber wheels.

**PIES**  
PIEDS  
STANDS



Base redonda regulable en altura.  
Base ronde réglable en hauteur.  
Height-adjustable round base.



SERIE 112 SL



Ref. 112 PE

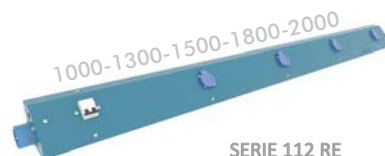

SERIE 112 RE

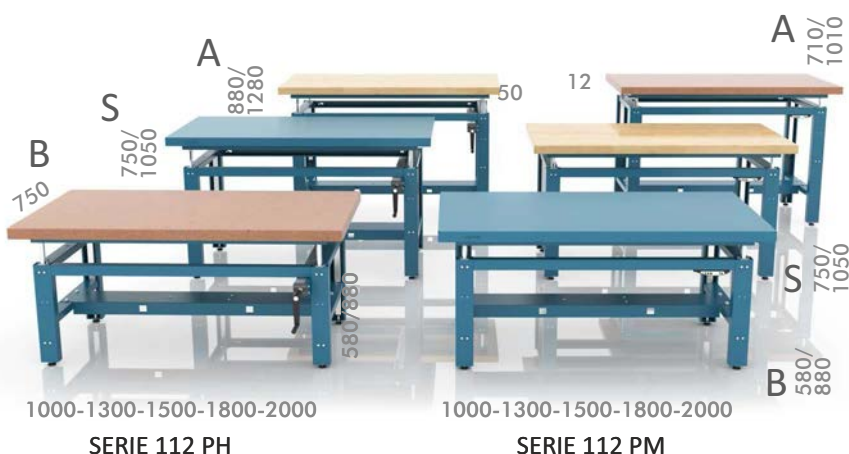

## INFORMACIÓN

### INFORMATION

### INFORMATION



SERIES 111 - 112 - 118 - 136 - 150  
Admiten cargas de 1000Kg.  
Des charges de 1000Kg sont autorisées.  
Loads of 1000Kg are allowed.



SERIES 112 PH-PM - 142      SERIES 120 137  
Admiten cargas de 600Kg-300Kg.  
Des charges de 600Kg - 300Kg sont autorisées.  
Loads of 600Kg-300Kg are allowed.



SERIES 121      SERIES 121 R  
Admiten cargas de 200Kg-180Kg.  
Des charges de 200Kg - 180Kg sont autorisées.  
Loads of 200Kg-180Kg are allowed.



Posibles encimeras / Plan de travail possibles / Possible worktops



e 40 - 50 mm

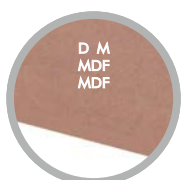

e 30 - 40 - 50 mm



e 30 - 40 - 50 mm

## BANCOS DE TRABAJO

### ETABLIS

### WORKBENCHES

- ES**
- Bancos de trabajo ergonómicos y confortables.
  - Disponibles con/sin ruedas.
  - Disponibles con/sin patas graduables (en altura).
  - Preparados para la fijación de 1 a 3 cajones (según modelo).
  - Encimeras disponibles:  
Chapa galvanizada/chapa pintada.  
Madera de castaño/tablero de DM.
  - Color estándar azul martelé posibilidad colores en opción.
- FR**
- Établis ergonomique et confortable.
  - Disponibles avec/sans roues.
  - Disponibles avec/sans pieds réglables (en hauteur).
  - Préparé pour le montage de 1 à 3 tiroirs (selon modèle).
  - Plan de travail disponibles: galvanisée/peint /châtaigner / MDF .
  - Couleur standard bleu martelé possibilité teintes en option.
- EN**
- Ergonomic and comfortable workbenches.
  - Available with /without wheels.
  - Available with/without adjustable legs (height).
  - Prepared to add 1 to 3 drawers (according to model).
  - Available worktops: galvanized/painted metal sheet/chestnut wood/MDF board.
  - Standard colour hammered blue possibility optional colours.

**SERIE 111**

**L** 1000-1500-2000

**H** 895

**C** **D** **e** 40 mm

**e** 1,5 mm

**100** **GS** (apertura 90%)  
(ouverture 90%)  
(90% opening)

Encimera en chapa (2mm) o DM.  
Plan de travail en tôle (2mm) ou MDF.  
Metal (2mm) or MDF worktop.

Banco de trabajo modular.  
Établis modulaire.  
Modular workbench.

Ref. 111 20  
L 2000

Ref. 111 15 C  
L 1500

Ref. 111 10  
L 1000

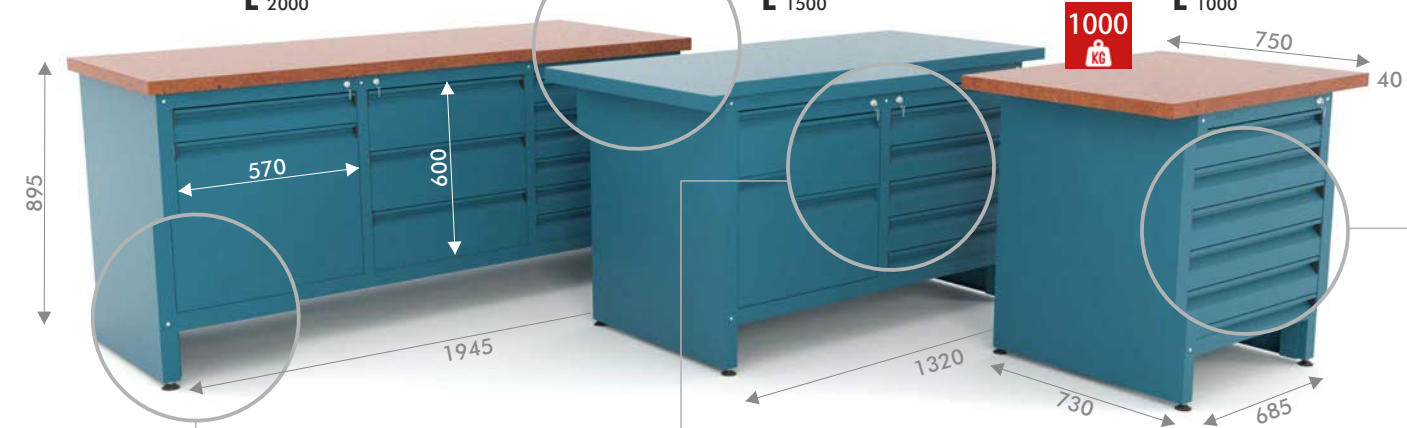

Base redonda regulable en altura.  
Base ronde réglable en hauteur.  
Height-adjustable round base. M12mm

Cierre centralizado.  
Fermeture centralisée.  
Centralized closing.

Los cajones incluyen una división en acero galvanizado.  
Les tiroirs inclus une division tôle galvanisée.  
Drawers include one galvanized sheet division.

Ref. 111 10  
100 Kg **D**

Ref. 111 15  
109 Kg **D**

Ref. 111 20  
133,5 Kg **D**

Ref. 111 10 C  
95 Kg **C**

Ref. 111 15 C  
102 Kg **C**

Ref. 111 20 C  
124,5 Kg **C**

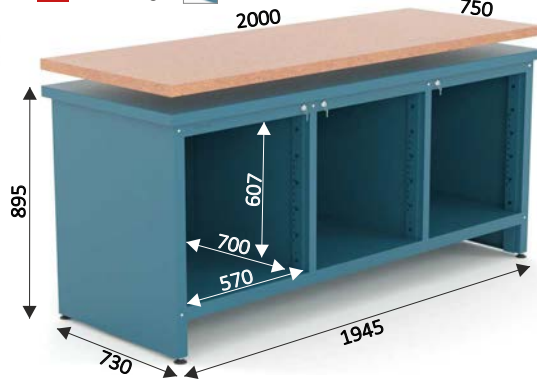
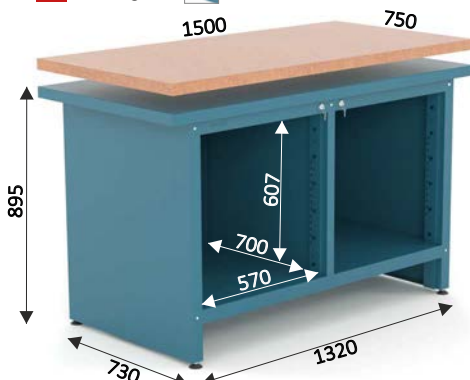
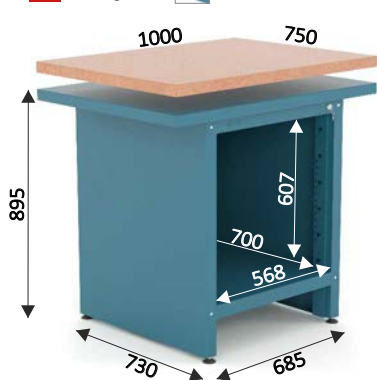

750 x 750 x 1140 mm

750 x 750 x 1640 mm

2000 x 800 x 1010 mm

**i** Los armazones no se sirven sin configuración de cajones y/o puertas.  
Les châssis ne sont pas fournis sans configuration de tiroirs et/ou de portes.  
Frames are not supplied without drawer and/or door configuration.

Accesorios opcionales  
Accessoires optionnels  
Optional accessories

Ref. 111 C 100

Se sirve con 1 división  
Servi avec 1 séparation  
Served with 1 division

7,5 Kg  
1 mm

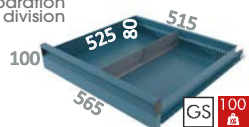

Ref. 111 C 200

Se sirve con 1 división  
Servi avec 1 séparation  
Served with 1 division

9 Kg  
1 mm

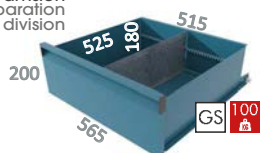

Ref. 111 PE

12 Kg



Ref. 111 BGI

4 Kg

1 mm

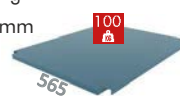

Ref. 111 BGCD

4 Kg

1 mm



Ref. 111 PG I  
Ref. 111 PG D

4,4 Kg

0,6mm



Ref. 111 PM I  
Ref. 111 PM D

3,6 Kg

0,6mm



Ref. 111 PP I  
Ref. 111 PP D

3,1 Kg

0,6mm



Gama de producto  
Gamme de produits  
Product range

L 1000

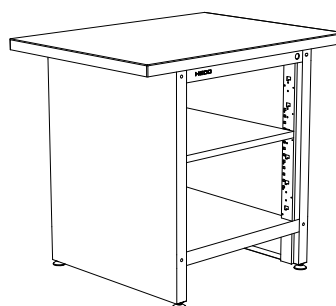

Ref. 111 10 01

  104 Kg

Ref. 111 10 01 C

  99 Kg

1u. Ref. 111 BG

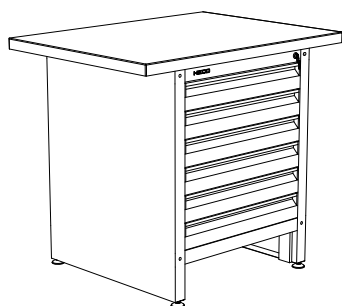

Ref. 111 10 02

  145 Kg

Ref. 111 10 02 C

  140 Kg

6u. Ref. 111 C 100



Ref. 111 10 03

  127 Kg

Ref. 111 10 03 C

  122 Kg

3u. Ref. 111 C 200

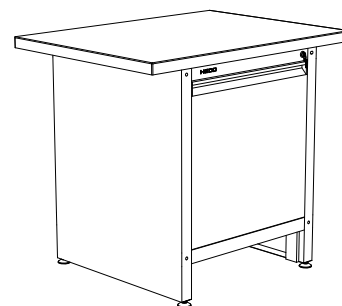

Ref. 111 10 04

  104 Kg

Ref. 111 10 04 C

  99 Kg

1u. Ref. 111 PG 1

Ref. 111 BG I

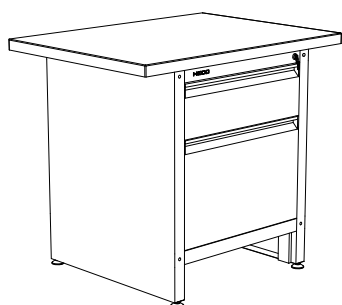

Ref. 111 10 05

  112 Kg

Ref. 111 10 05 C

  107Kg

1u. Ref. 111 C 200

1u. Ref. 111 PP I

Ref. 111 BG I

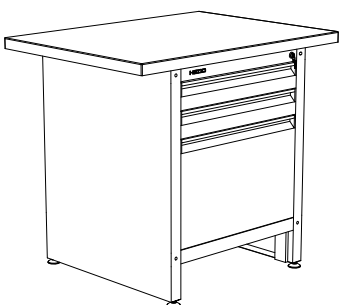

Ref. 111 10 06

  118 Kg

Ref. 111 10 06 C

  113 Kg

2u. Ref. 111 C 100

1u. Ref. 111 PP I

Ref. 111 BG I

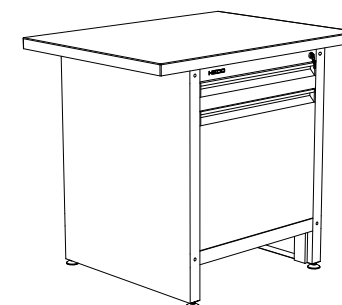

Ref. 111 10 07

  111 Kg

Ref. 111 10 07 C

  106 Kg

1u. Ref. 111 C 100

1u. Ref. 111 PM I

Ref. 111 BG I

## SERIE 111

Gama de producto  
Gamme de produits  
Product range

L 1500

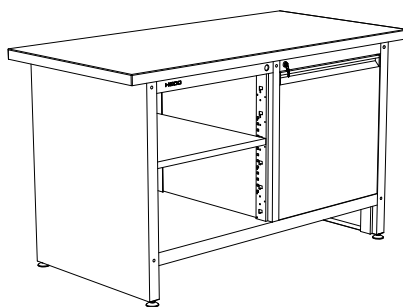

Ref. 111 15 01



 117 Kg

Ref. 111 15 01 C

 110 Kg

 1u. Ref. 111 BG I  
 1u. Ref. 111 PG D

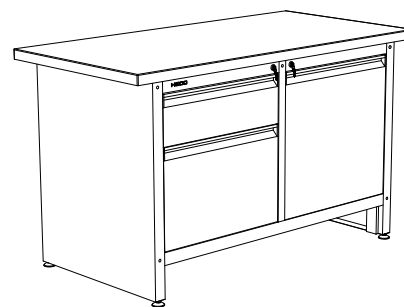
Ref. 111 BGCD



Ref. 111 15 02



 125 Kg

Ref. 111 15 02 C

 118 Kg

 1u. Ref. 111 C 200  
 1u. Ref. 111 PP I  
 1u. Ref. 111 PG D

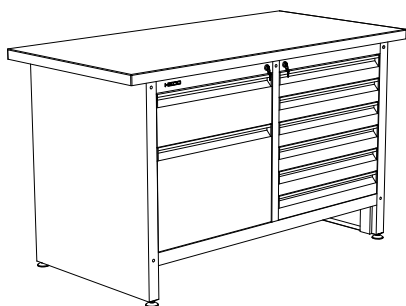
Ref. 111 BGCD



Ref. 111 15 03



 166 Kg

Ref. 111 15 03 C

 159 Kg

 1u. Ref. 111 C 200  
 1u. Ref. 111 PP I  
 6u. Ref. 111 C 100

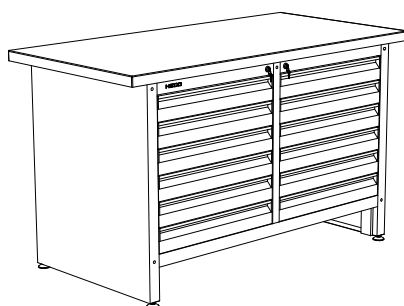
Ref. 111 BGCD



Ref. 111 15 04

 199 Kg

Ref. 111 15 04 C

 192 Kg

12u. Ref. 111 C 100

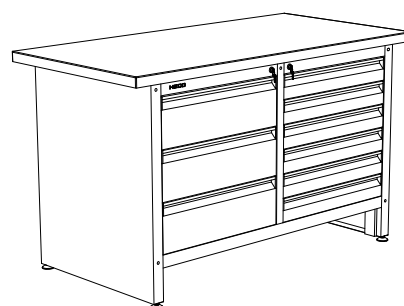

Ref. 111 15 05

 181 Kg

Ref. 111 15 05 C

 174 Kg

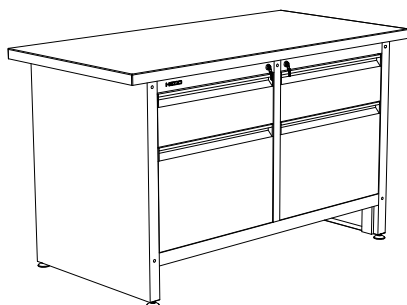
 3u. Ref. 111 C 200  
 6u. Ref. 111 C 100

Ref. 111 15 06



 130 Kg

Ref. 111 15 06 C

 123 Kg

 1u. Ref. 111 C 200  
 1u. Ref. 111 PP I  
 1u. Ref. 111 C 200  
 1u. Ref. 111 PP D

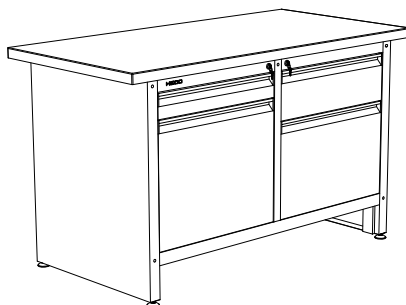
Ref. 111 BGI-BGCD



Ref. 111 15 07



 132 Kg

Ref. 111 15 07 C

 125 Kg

 1u. Ref. 111 C 100  
 1u. Ref. 111 PM I  
 1u. Ref. 111 C 200  
 1u. Ref. 111 PP D

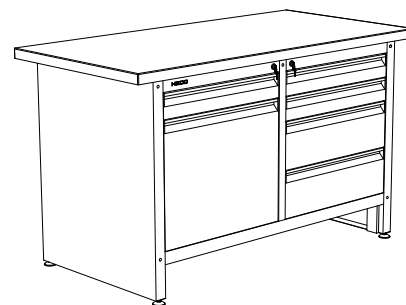
Ref. 111 BGI-BGCD



Ref. 111 15 08

 153 Kg

Ref. 111 15 08 C



 146 Kg

 1u. Ref. 111 C 100  
 1u. Ref. 111 PM I  
 3u. Ref. 111 C 100  
 2u. Ref. 111 C 200

Ref. 111 BGCD

Gama de producto  
Gamme de produits  
Product range

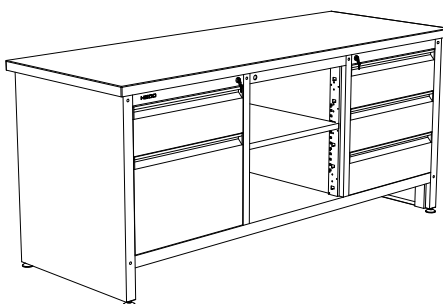
L 2000



Ref. 111 20 01

  177 Kg

Ref. 111 20 01 C

  168 Kg

1u. Ref. 111 C 200 1u. Ref. 111 PP I

1u. Ref. 111 BGCD 3u. Ref. 111 C 200

Ref. 111 BG I

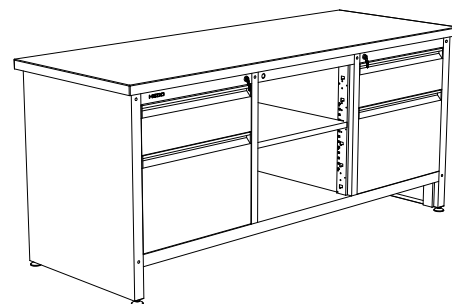

Ref. 111 20 02

  163 Kg

Ref. 111 20 02 C

  154 Kg

1u. Ref. 111 C 200 1u. Ref. 111 PP I 1u. Ref. 111 BGCD

1u. Ref. 111 C 200 1u. Ref. 111 PP D

Ref. 111 BGI-BGCD

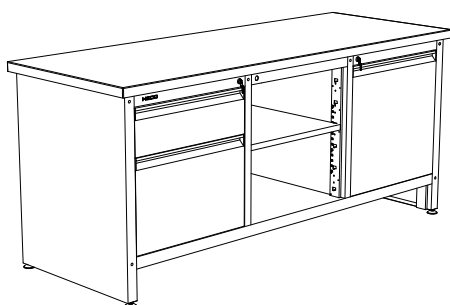

Ref. 111 20 03

  154 Kg

Ref. 111 20 03 C

  145 Kg

1u. Ref. 111 C 200 1u. Ref. 111 PP I

1u. Ref. 111 BGCD 1u. Ref. 111 PG D

Ref. 111 BGI- BGCD

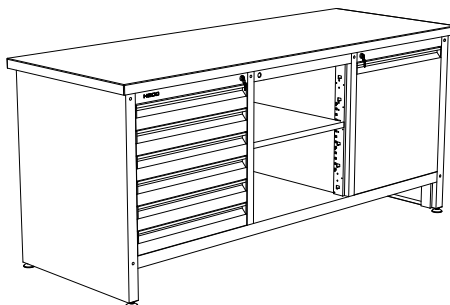

Ref. 111 20 04

  187 Kg

Ref. 111 20 04 C

  178 Kg

6u. Ref. 111 C 100 1u. Ref. 111 BGCD 1u. Ref. 111 PG D

Ref. 111 BGCD

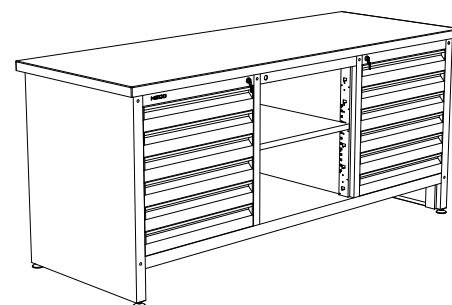

Ref. 111 20 05

  228 Kg

Ref. 111 20 05 C

  219 Kg

6u. Ref. 111 C 100 1u. Ref. 111 BGCD 6u. Ref. 111 C 100

Ref. 111 BGI-BGCD

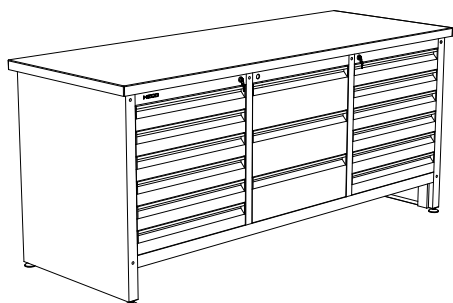

Ref. 111 20 06

  251 Kg

Ref. 111 20 06 C

  242 Kg

6u. Ref. 111 C 100 3u. Ref. 111 C 200 6u. Ref. 111 C 100

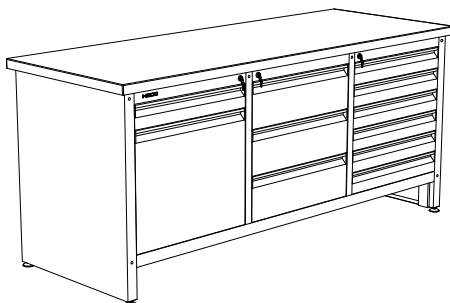

Ref. 111 20 07

  217 Kg

Ref. 111 20 07 C

  208 Kg

1u. Ref. 111 C 100 1u. Ref. 111 PM I

3u. Ref. 111 C 200 6u. Ref. 111 C 100

Ref. 111 BGI

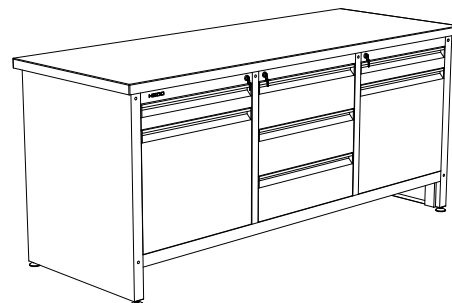

Ref. 111 20 08

  182 Kg

Ref. 111 20 08 C

  173 Kg

1u. Ref. 111 C 100 1u. Ref. 111 PM I 3u. Ref. 111 C 200

1u. Ref. 111 C 100 1u. Ref. 111 PM D

Ref. 111 BGI-BGCD

## SERIE 112

L 1000-1300-1500-1800-2000

H 880

 e 50 mm

 2 mm

Banco de trabajo con patas fijas, graduables o ruedas.  
Établis avec pieds fixes, pieds réglables ou roues.  
Modular workbench with fixed or adjustable legs, or wheels.

Encimeras: Chapa, DM y madera Castaño.  
Plans de travail : Tôle, MDF et bois de châtaignier.  
Worktops: Sheet, MDF and Chestnut wood.

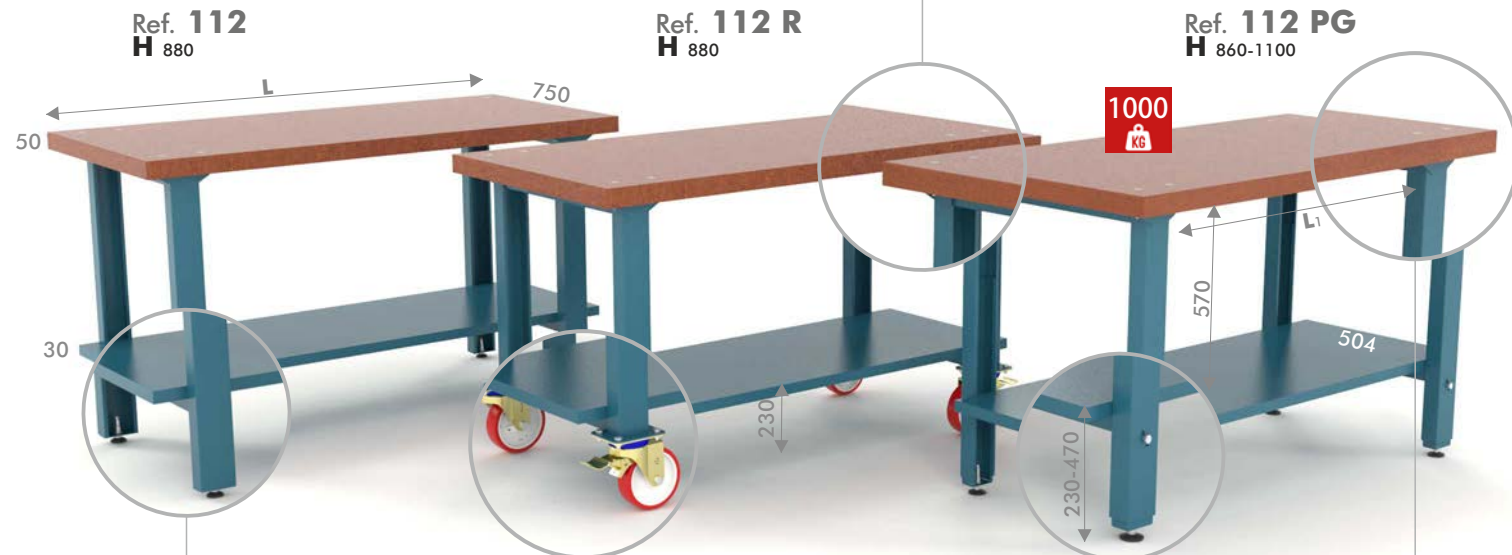

Ref. 112  
H 880

Ref. 112 R  
H 880

Ref. 112 PG  
H 860-1100

 Base regulable en altura en estructura.  
Base réglable en hauteur dans la structure.  
Height-adjustable round base in structure.

4 giratorias (2 con freno).  
4 pivotantes (2 avec frein).  
4 swivel wheels (2 with brake).

Tornillos enrasados en encimeras de madera.  
Vis affleurantes sur les plans de travail en bois.  
Flush screws on wooden worktops.

M12mm



Ø= 150 mm  
H= 196 mm  



La altura se regula cada 40mm.  
La hauteur est réglée chaque 40 mm.  
The height is regulated every 40mm.



Se entrega desmontado. OPCIÓN (entrega montado). Montaje con tornillos, incluidos.  
Livraison démonté. OPTIONNEL (livraison assemblée). Assemblage avec vis, inclus.  
Supplied disassembled. OPTIONAL (assembled supplied). Assembly with screws, included.



Cajones admitidos. **SERIE 129** **SERIE 113**  
Tiroirs admis. **SERIE 132** **SERIE 153**  
Admitted drawers. **SERIE 133** Pg. 107

### Accesorios opcionales Accessoires optionnels Optional accessories

#### Ref. 112 P

 8,05 Kg  
Una unidad.  
Une unité.  
A unit.

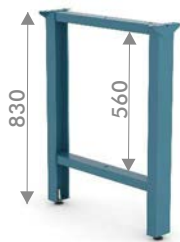

#### Ref. 112 P R

 13,55 Kg  
Un juego de dos unidades.  
Un jeu (2 unités).  
One set of two units.

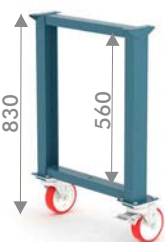

#### Ref. 112 PG

 21,70 Kg  
Juego de dos.  
Une jeu.  
One set.



#### Ref. 112 PE

 24 Kg  
Pata eléctrica.  
Pied électrique.  
Electric leg.



#### Ref. 145 CTP

 10 Kg  
 2mm  
Juego de dos.  
Une jeu.  
One set.

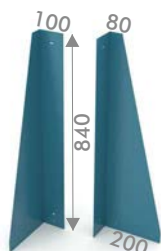

#### SERIE 112 SL

SopORTE luminária.  
Support d'éclairage.  
Lighting support.



#### SERIE 112 R P

Barra de refuerzo.  
Barre de renfort.  
Reinforcement.

Ref. 112 R P 10 3 Kg L 787  
Ref. 112 R P 13 3,7 Kg L 1117  
Ref. 112 R P 15 4,2 Kg L 1337  
Ref. 112 R P 18 5,3 Kg L 1667  
Ref. 112 R P 20 5,6 Kg L 1777



#### SERIE 112 B

Bandeja inferior.  
Plateau inférieur.  
Bottom tray.

Ref. 112 B 10 9,5 Kg L 1000  
Ref. 112 B 13 12,5 Kg L 1300  
Ref. 112 B 15 14,75 Kg L 1500  
Ref. 112 B 18 17,6 Kg L 1800  
Ref. 112 B 20 19,3 Kg L 2000



#### SERIE 112 E C

Encimera chapa.  
Plan de travail tôle.  
Sheet worktop.



Ref. 112 E C 10 20,1 Kg  
Ref. 112 E C 13 26,3 Kg  
Ref. 112 E C 15 30,75 Kg  
Ref. 112 E C 18 36,2 Kg  
Ref. 112 E C 20 41,1 Kg

L 1000-1300-1500-1800-2000

#### SERIE 112 E DM

Encimera DM.  
Plan de travail MDF.  
MDF worktop.



Ref. 112 E DM 10 25,1 Kg  
Ref. 112 E DM 13 30,65 Kg  
Ref. 112 E DM 15 37,4 Kg  
Ref. 112 E DM 18 44,9 Kg  
Ref. 112 E DM 20 49,8 Kg

L 1000-1300-1500-1800-2000

#### SERIE 112 E M

Encimera madera Castaño.  
Plan de travail bois châtaignier.  
Chestnut wood worktop.



Ref. 112 E M 10 22,3 Kg  
Ref. 112 E M 13 28,6 Kg  
Ref. 112 E M 15 33,2 Kg  
Ref. 112 E M 18 39,6 Kg  
Ref. 112 E M 20 44 Kg

L 1000-1300-1500-1800-2000

L 1000-1300-1500-1800-2000

Gama de producto  
Gamme de produits  
Product range

Ref. 112



Ref. 112 R



Ref. 112 PG



**L 1000 L<sub>1</sub> 654**

Ref. 112 10 PG 48 Kg  
Ref. 112 10 D PG 56 Kg  
Ref. 112 10 M PG 51 Kg

**L 1000 L<sub>1</sub> 654**

Ref. 112 10 R 60 Kg  
Ref. 112 10 D R 67 Kg  
Ref. 112 10 M R 63 Kg

**L 1000 L<sub>1</sub> 654**

Ref. 112 10 48 Kg  
Ref. 112 10 D 56 Kg  
Ref. 112 10 M 51 Kg

**L 1300 L<sub>1</sub> 954**

Ref. 112 13 PG 58 Kg  
Ref. 112 13 D PG 64 Kg  
Ref. 112 13 M PG 60 Kg

**L 1300 L<sub>1</sub> 954**

Ref. 112 13 R 70 Kg  
Ref. 112 13 D R 76 Kg  
Ref. 112 13 M R 72 Kg

**L 1300 L<sub>1</sub> 954**

Ref. 112 13 58 Kg  
Ref. 112 13 D 64 Kg  
Ref. 112 13 M 60 Kg

**L 1500 L<sub>1</sub> 1154**

Ref. 112 15 PG 66 Kg  
Ref. 112 15 D PG 71 Kg  
Ref. 112 15 M PG 68 Kg

**L 1500 L<sub>1</sub> 1154**

Ref. 112 15 R 78 Kg  
Ref. 112 15 D R 83 Kg  
Ref. 112 15 M R 80 Kg

**L 1500 L<sub>1</sub> 1154**

Ref. 112 15 66 Kg  
Ref. 112 15 D 71 Kg  
Ref. 112 15 M 68 Kg

**L 1800 L<sub>1</sub> 1454**

Ref. 112 18 PG 76 Kg  
Ref. 112 18 D PG 82 Kg  
Ref. 112 18 M PG 77 Kg

**L 1800 L<sub>1</sub> 1454**

Ref. 112 18 R 88 Kg  
Ref. 112 18 D R 94 Kg  
Ref. 112 18 M R 89 Kg

**L 1800 L<sub>1</sub> 1454**

Ref. 112 18 76 Kg  
Ref. 112 18 D 82 Kg  
Ref. 112 18 M 77 Kg

**L 2000 L<sub>1</sub> 1654**

Ref. 112 20 PG 83 Kg  
Ref. 112 20 D PG 92 Kg  
Ref. 112 20 M PG 83 Kg





**L 2000 L<sub>1</sub> 1654**

Ref. 112 20 R 95 Kg  
Ref. 112 20 D R 104 Kg  
Ref. 112 20 M R 95 Kg

**L 2000 L<sub>1</sub> 1654**

Ref. 112 20 83 Kg  
Ref. 112 20 D 92 Kg  
Ref. 112 20 M 83 Kg

**SERIE 112 PH-112 PM**
**L** 1000-1300-1500-1800-2000



**e** 50 mm
 
**e** 12 mm

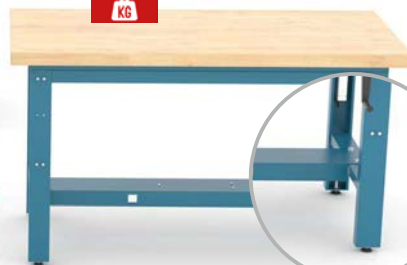

**e** 2 mm

 Banco de trabajo con sistema hidráulico o motorización eléctrica.  
 Établi avec système hydraulique ou motorisation électrique.  
 Workbench with hydraulic system or electric motorization.

**SERIE 112 PH S**
**H** min. 750 mm  
 max. 1050 mm

**SERIE 112 PH A**
**H** min. 880 mm  
 max. 1180 mm

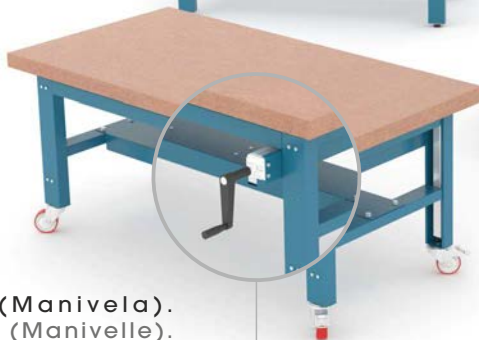
**SERIE 112 PH B**
**Hr** min. 700 mm  
 max. 1000 mm

**SERIE 112 PM-PH R**

 Referencia Ruedas.  
 Référence Roues.  
 Wheels Reference.

 SISTEMA HIDRÁULICO **PH** (Manivela).  
 SYSTÈME HYDRAULIQUE **PH** (Manivelle).  
 HYDRAULIQUE SYSTEM **PH** (Crank handle).

 Recorrido de 300 mm.  
 300 mm de course.  
 300 mm path.

 Base regulable en altura.  
 Base réglable en hauteur.  
 Height-adjustable round base.

M12mm

**SERIE 112 PM S**
**H** min. 750 mm  
 max. 1050 mm

**600**

**SERIE 112 PM A**
**H** min. 880 mm  
 max. 1180 mm

**SERIE 112 PM B**
**H** min. 610 mm  
 max. 910 mm

 SISTEMA ELÉCTRICO  
 SYSTÈME ÉLECTRIQUE  
 ELECTRIC SYSTEM

**PM** (Panel de control).  
**PM** (Panneau de contrôle).  
**PM** (Control panel).

 Accesorios opcionales  
 Accessoires optionnels  
 Optional accessories

 Referencias  
 Références  
 References

**Ref. 112 PM-PH R**

 Juego de ruedas giratorias (2 con freno).  
 Jeu de roulettes pivotantes (2 avec freins).  
 Set of swivel castors (2 with brakes).

**H** 106 mm  $\varnothing$  80 mm

 Encimeras  
 Plans de travail  
 Worktops

**ELECCIÓN SERIE**

 CHOIX DE SÉRIE  
 CHOICE SERIE

 REF. **112**

<b>L</b>	<b>C/D/M</b>	<b>PM/PH</b>	<b>30</b>	<b>A/S/B</b>
1	2	3		4

 1) **L** 1000/1300/1500/1800/2000

 2) **x C / D / M** Encimera - Plan de travail - Worktop

 3) **SERIE 112 PM/PH**

 4) **SERIE A**
**H** min. 880 mm  
 max. 1180 mm

**SERIE S**
**H** min. 750 mm  
 max. 1050 mm

**SERIE B**
**H** min. 610 mm  
 max. 910 mm

 Chapa.  
 Tôle.  
 Sheet.

 DM.  
 MDF.  
 MDF.

 Madera Castaño.  
 Bois châtaigner.  
 Chesnut wood.

## SERIE 112 PH-112 PM

Gama de producto  
Gamme de produits  
Product range

## SERIE 112 PH



## SERIE 112 PM



	<b>L 1000</b>			
	X	C	D	M
Ref. 112 10 x PH 30 A	39,55	43,42	41,25	
Ref. 112 10 x PH 30 S	50,91	55,91	53,11	
Ref. 112 10 x PH 30 B	59,57	65,43	62,15	

	<b>L 1300</b>			
	X	C	D	M
Ref. 112 13 x PH 30 A	50,16	53,60	51,93	
Ref. 112 13 x PH 30 S	64,63	69,09	66,93	
Ref. 112 13 x PH 30 B	75,66	80,89	78,36	

	<b>L 1500</b>			
	X	C	D	M
Ref. 112 15 x PH 30 A	57,60	62,74	59,49	
Ref. 112 15 x PH 30 S	74,26	80,91	76,71	
Ref. 112 15 x PH 30 B	86,96	94,76	88,96	

	<b>L 1800</b>			
	X	C	D	M
Ref. 112 18 x PH 30 A	67,24	73,96	69,86	
Ref. 112 18 x PH 30 S	86,73	95,43	90,13	
Ref. 112 18 x PH 30 B	101,58	111,79	105,57	

	<b>L 2000</b>			
	X	C	D	M
Ref. 112 20 x PH 30 A	75,03	81,76	77,27	
Ref. 112 20 x PH 30 S	96,81	105,51	99,71	
Ref. 112 20 x PH 30 B	113,41	123,61	116,81	

	<b>L 1000</b>			
	X	C	D	M
Ref. 112 10 x PM 30 A	38,68	42,55	40,38	
Ref. 112 10 x PM 30 S	50,04	55,04	52,24	
Ref. 112 10 x PM 30 B	58,70	64,56	61,28	

	<b>L 1300</b>			
	X	C	D	M
Ref. 112 13 x PM 30 A	49,29	52,73	51,06	
Ref. 112 13 x PM 30 S	63,76	68,22	66,06	
Ref. 112 13 x PM 30 B	74,79	80,02	77,49	

	<b>L 1500</b>			
	X	C	D	M
Ref. 112 15 x PM 30 A	56,73	61,87	58,62	
Ref. 112 15 x PM 30 S	73,39	80,04	75,84	
Ref. 112 15 x PM 30 B	86,09	93,89	88,09	

	<b>L 1800</b>			
	X	C	D	M
Ref. 112 18 x PM 30 A	66,37	73,09	68,99	
Ref. 112 18 x PM 30 S	85,86	94,56	89,26	
Ref. 112 18 x PM 30 B	100,71	110,92	104,70	

	<b>L 2000</b>			
	X	C	D	M
Ref. 112 20 x PM 30 A	94,16	80,89	76,40	
Ref. 112 20 x PM 30 S	95,94	104,64	98,84	
Ref. 112 20 x PM 30 B	112,54	122,74	115,94	

**SERIE 118**
**L** 1000-1800

**H** 880

**e** 50 mm

**e** 1,5 mm

 (apertura 90%)  
(ouverture 90%)  
(90% opening)

 Opciones encimera; CHAPA 3 mm.  
Options plan de travail; TÔLE 3 mm.  
Worktop options; STEEL 3 mm.

 Estantería fija.  
Étagère fixe.  
Fixed shelf.

 Banco monobloque de alta resistencia.  
Établis monobloc de haute résistance.  
Monoblock workbench of high resistance.

 MÁXIMO 4 CAJONES  
MAXIMUM 4 TIROIRS  
MAXIMUM 4 DRAWERS

 Cierre persiana.  
Fermeture a rideau.  
Shutter closing.

Ref. 118

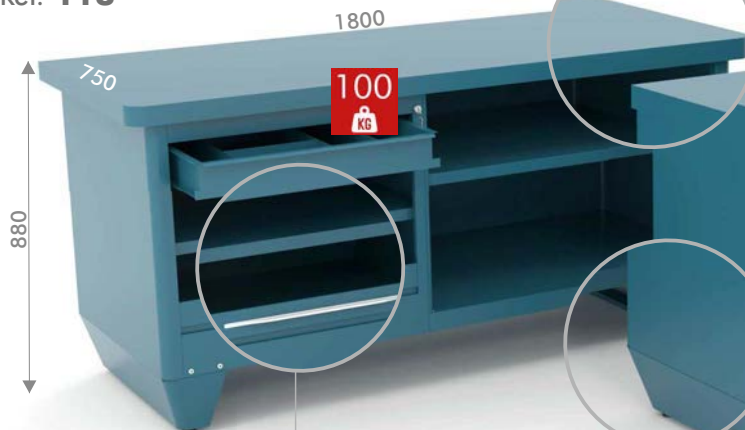
 Cajón y estantería graduable.  
Tiroir et étagère réglable.  
Drawer and amovable shelf.

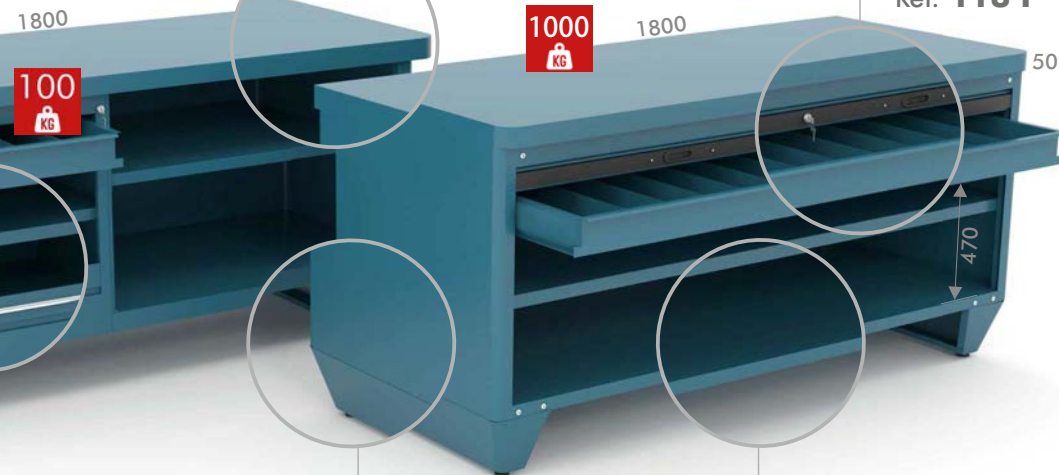
 MÁXIMO 1 CAJÓN  
MAXIMUM 1 TIROIR  
MAXIMUM 1 DRAWER

 Estantería graduable.  
Étagère réglable.  
Amovable shelf.

 Estructura totalmente soldada.  
Structure totalement soudée.  
Total welded structure.

 Base regulable en altura.  
Base réglable en hauteur.  
Height-adjustable round base. M12mm

**e** 1,2 mm

 Gama de producto  
Gamme de produits  
Product range

**L** 1800 mm

Ref. 118

 142 Kg

**H** 50 mm

Ref. 118 D

 151 Kg

**H** 50 mm

Ref. 118 M

 144 Kg

**H** 50 mm

**L** 1800 mm

Ref. 118 18 P

 142 Kg

**H** 50 mm

Ref. 118 18 PD

 151 Kg

**H** 50 mm

Ref. 118 18 PM

 144 Kg

**H** 50 mm

 Accesorios  
Accessoires  
Accessories

Ref. 118 C

 7,5 Kg

**C** 75 mm

Ref. 118 18 C

 20 Kg

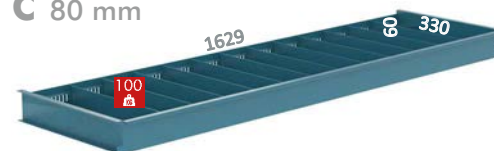
**C** 80 mm

## SERIE 120

**L** 1000  
**H** 840  
  **e** 40 mm  
 **e** 2 mm

Banco plegable. Totalmente rígido gracias a su sistema de plegado.  
 Établis pliant. Absolument rigide grâce au système de pliage.  
 Folding workbench. Our folding system ensures complete rigidity.

Ref. **120 10 1**

 23,62 Kg

 **H** 40 mm

D M  
 MDF  
 MDF

Dos asas para facilitar el transporte.  
 Deux poignées pour faciliter le transport.  
 Two handles for easy transport.



Ref. **120 10 5**

 21,60 Kg

 **H** 40 mm

Chapa galvanizada  
 Tôle galvanisée  
 Galvanized metal sheet



Base de las patas con conteras especiales de plástico.  
 Base des pieds avec embouts spéciaux en plastique.  
 Base of the legs with special plastic ends.



Montaje con tornillos (se entrega desmontado).  
 Montage avec vis (livraison démonté).  
 Screw assembly (supplied disassembled).



Fácilmente transportable, registrado como modelo de utilidad 930 10 89.  
 Facilement transportable, enregistré comme modèle d'utilité 930 10 89.  
 Easy transport, registered like 930 10 89 utility model.

## SERIE 121

**L** 1000-1500-2000

**L<sub>1</sub>** 845-1345-1845

**H** 840

**e** 40 mm

**e** 2 mm

Banco de trabajo con bandeja inferior en chapa galvanizada y graduable en altura.  
Table de travail avec plateau inférieur en tôle galvanisée et réglable en hauteur.  
Workbench with inferior galvanized steel tray and adjustable in height.



Ref. **121 5 R**  
**H** 40 mm

Chapa galvanizada  
Tôle galvanisée  
Galvanized metal sheet

Admite cajón SERIE 132.  
Permet le tiroir SERIE 132.  
Enables drawer SERIE 132.

Ref. **121 1**  
**H** 40 mm

D M  
MDF  
MDF

Ruedas de goma giratorias 2 con freno.  
Roues en caoutchouc pivotant 2 avec frein.  
Rubber wheels swivel 2 with brake.



Ø 100mm  
H 135mm



Montaje con tornillos (se entrega desmontado).  
Montage avec vis (livraison démonté).  
Screw assembly (supplied disassembled).

Estanteria inferior graduable cada 50 mm.  
Étagère inférieure réglable chaque 50 mm.  
Bottom shelf adjustable every 50 mm.

**H** 30 mm  
Ref. **121 0 01**  
5,65 Kg L 986 mm

Chapa galvanizada  
Tôle galvanisée  
Galvanized metal sheet  
Ref. **121 0 15**  
8,37 Kg L 1486 mm

**e** 1,2 mm  
Ref. **121 0 20**  
11,09 Kg L 1986 mm

Gama de producto  
Gamme de produits  
Product range



Ref. **121 10 1**  
**L** 1000 1 KG 30 Kg

Ref. **121 10 5**  
**L** 1000 5 KG 26 Kg

Ref. **121 15 1**  
**L** 1500 1 KG 40 Kg

Ref. **121 15 5**  
**L** 1500 5 KG 30 Kg

Ref. **121 20 1**  
**L** 2000 1 KG 53 Kg

Ref. **121 20 5**  
**L** 2000 5 KG 44 Kg



Ref. **121 10 1 1C**  
**L** 1000 1 KG 39 Kg

Ref. **121 10 5 1C**  
**L** 1000 5 KG 35 Kg

Ref. **121 15 1 1C**  
**L** 1500 1 KG 49 Kg

Ref. **121 15 5 1C**  
**L** 1500 5 KG 39 Kg

Ref. **121 20 1 1C**  
**L** 2000 1 KG 62 Kg

Ref. **121 20 5 1C**  
**L** 2000 5 KG 53 Kg

Gama de producto  
Gamme de produits  
Product range



Ref. **121 15 1 2C**  
**L 1500**  58 Kg  
2u. SERIE 132

Ref. **121 15 5 2C**  
**L 1500**  48 Kg  
2u. SERIE 132

Ref. **121 20 1 2C**  
**L 2000**  71 Kg  
2u. SERIE 132

Ref. **121 20 5 2C**  
**L 2000**  62 Kg  
2u. SERIE 132



Ref. **121 20 1 3C**  
**L 2000**  80 Kg  
3u. SERIE 132

Ref. **121 20 5 3C**  
**L 2000**  71 Kg  
3u. SERIE 132



Ref. **121 10 1 R**  
**L 1000**  33 Kg

Ref. **121 10 5 R**  
**L 1000**  29 Kg

Ref. **121 15 1 R**  
**L 1500**  43 Kg

Ref. **121 15 5 R**  
**L 1500**  33 Kg

Ref. **121 20 1 R**  
**L 2000**  56 Kg

Ref. **121 20 5 R**  
**L 2000**  47 Kg



Ref. **121 10 1 R 1C**  
**L 1000**  42 Kg  
1u. SERIE 132

Ref. **121 10 5 R 1C**  
**L 1000**  38 Kg  
1u. SERIE 132

Ref. **121 15 1 R 1C**  
**L 1500**  52 Kg  
1u. SERIE 132

Ref. **121 15 5 R 1C**  
**L 1500**  42 Kg  
1u. SERIE 132

Ref. **121 20 1 R 1C**  
**L 2000**  65 Kg  
1u. SERIE 132

Ref. **121 20 5 R 1C**  
**L 2000**  56 Kg  
1u. SERIE 132



Ref. **121 15 1 R 2C**  
**L 1500**  61 Kg  
2u. SERIE 132

Ref. **121 15 5 R 2C**  
**L 1500**  51 Kg  
2u. SERIE 132

Ref. **121 20 1 R 2C**  
**L 2000**  74 Kg  
2u. SERIE 132

Ref. **121 20 5 R 2C**  
**L 2000**  65 Kg  
2u. SERIE 132



Ref. **121 20 1 R 3C**  
**L 2000**  83 Kg  
3u. SERIE 132

Ref. **121 20 5 R 3C**  
**L 2000**  74 Kg  
3u. SERIE 132

**SERIE 136**
**L** 1500-1800-2000

**H** 880

**e** 50 mm

**e** 2 mm

**GS** (apertura 90%)  
(ouverture 90%)  
(90% opening)

 Banco de trabajo configurable; armarios / cajones / patas.  
 Établis personnalisé; armoires / tiroirs / pieds.  
 Customizable workbench; cabinets / drawers / legs.

 Encimeras: Chapa, DM y madera Castaño.  
 Plans de travail : Tôle, MDF et bois de châtaignier.  
 Worktops: Sheet, MDF and Chestnut wood.

 Admite cajones para banco.  
 Admet les tiroirs des établis.  
 Admits workshops drawers

 Ref. **136 20 22**

 Ref. **136 18 2**

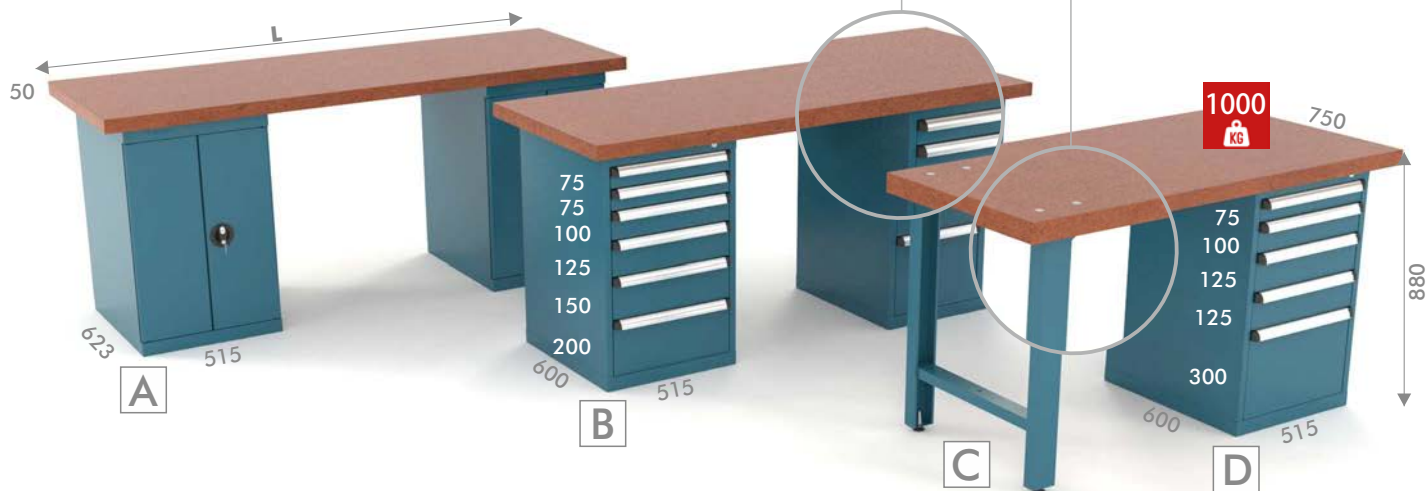
 Ref. **136 15 1**

**A**

 Ref. **136 1**

 Armario con bandeja SERIE 125 BG  
 Armoire avec étagère SERIE 125 BG  
 Cabinet with shelf SERIE 125 BG

 41 Kg

**B**

 Ref. **136 2 2**

 Armario con cajones SERIE 135  
 Armoire avec tiroirs SERIE 135  
 Cabinet with drawers SERIE 135

 67 Kg

 1 división ranurada y 3 planos.  
 1 division rainuré et 3 intercalaires.  
 1 slotted division and 3 simples.

**C**

 Ref. **112 P**

 Pata para banco de trabajo  
 Pied pour établi de travail  
 Feet for workbenches

 6,05 Kg

**D**

 Ref. **136 2 1**

 Armario con cajones SERIE 135  
 Armoire avec tiroirs SERIE 135  
 Cabinet with drawers SERIE 135

 62 Kg

 Se entrega montado.  
 Livraison montée.  
 Supplied assembled.

 Gama de producto  
 Gamme de produits  
 Product range

**L 1500**

 1u. Ref. 112 P  
 1u. Ref. 136 2 1

 Ref. **136 15 C 1**

 Ref. **136 15 D 1**

 Ref. **136 15 M 1**

 102 Kg

 110 Kg

 105 Kg

**L 1800**

 1u. Ref. 112 P  
 1u. Ref. 136 2 1

 Ref. **136 18 C 1**

 Ref. **136 18 D 1**

 Ref. **136 18 M 1**

 111 Kg

 121 Kg

 111 Kg

**L 2000**

 1u. Ref. 112 P  
 1u. Ref. 136 2 1

 Ref. **136 20 C 1**

 Ref. **136 20 D 1**

 Ref. **136 20 M 1**

 117 Kg

 129 Kg

 115 Kg

Gama de producto  
Gamme de produits  
Product range



**L 1800**  
1u. Ref. 136 2 1  
1u. Ref. 136 2 2

Ref. **136 18 C 2**

Ref. **136 18 D 2**

Ref. **136 18 M 2**

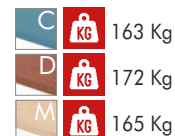

**L 2000**  
1u. Ref. 136 2 1  
1u. Ref. 136 2 2

Ref. **136 20 C 2**

Ref. **136 20 D 2**

Ref. **136 20 M 2**

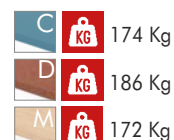

**L 1500**  
1u. Ref. 112 P  
1u. Ref. 136 1

Ref. **136 15 C 11**

Ref. **136 15 D 11**

Ref. **136 15 M 11**

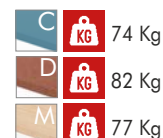

**L 1800**  
1u. Ref. 112 P  
1u. Ref. 136 1

Ref. **136 18 C 11**

Ref. **136 18 D 11**

Ref. **136 18 M 11**

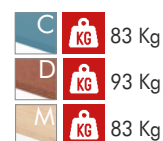

**L 1800**  
1u. Ref. 136 2 1  
1u. Ref. 136 1

Ref. **136 18 C 21**

Ref. **136 18 D 21**

Ref. **136 18 M 21**

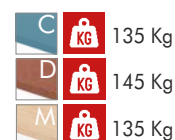

**L 2000**  
1u. Ref. 136 2 1  
1u. Ref. 136 1

Ref. **136 20 C 21**

Ref. **136 20 D 21**

Ref. **136 20 M 21**

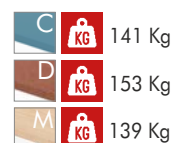

**L 1800**  
2u. Ref. 136 1

Ref. **136 18 C 22**

Ref. **136 18 D 22**

Ref. **136 18 M 22**

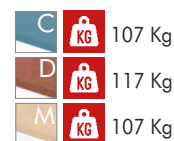

**L 2000**  
2u. Ref. 136 1

Ref. **136 20 C 22**

Ref. **136 20 D 22**

Ref. **136 20 M 22**

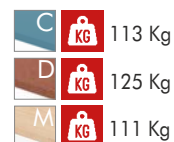

## SERIE 142

**L** 1500-1800-2000

**L<sub>1</sub>** 1400-1700-1900

**L<sub>2</sub>** 1220-1520-1720

**H** 840 + e

**C** e 50 mm **D** e 40 mm

**e** 1,5 mm

Banco de trabajo ideal: calidad y robustez HECO simplificada sin perder la esencia.  
Établi idéal :Qualité et robustesse des HECO simplifiées sans perdre l'essentiel.  
Ideal workbench: HECO quality and robustness simplified without losing the essence.

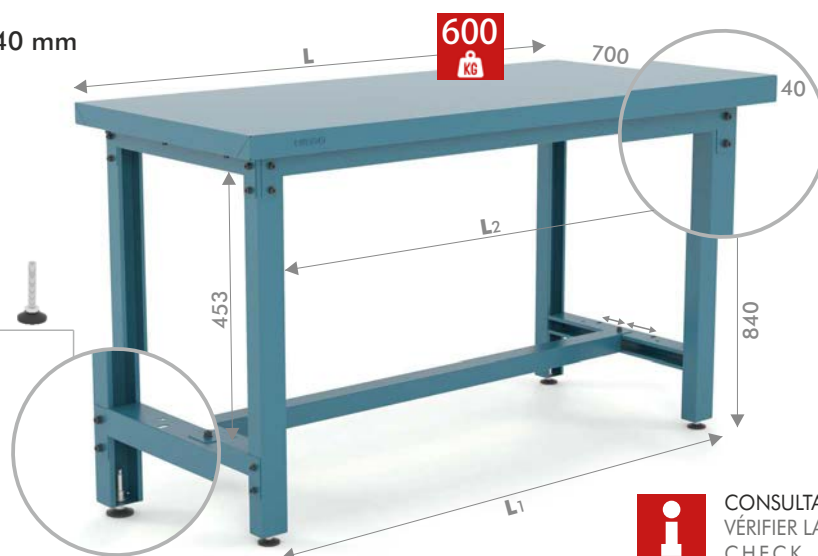

Pies ajustables en altura.  
Pieds réglables en hauteur  
Feet adjustable in height.

Montaje fácil con tornillos.  
Montage facile à l'aide de vis.  
Easy assembly with screws.



Se entrega desmontado.  
Livraison démonté.  
Supplied disassembled.



CONSULTAR DISPONIBILIDAD Hasta fin de existencias  
VÉRIFIER LA DISPONIBILITÉ Jusqu'à épuisement du stock  
CHECK AVAILABILITY Until end of stock

Gama de producto  
Gamme de produits  
Product range

**L** 1800 mm

Ref. 142 18 A C

**C** H 50 mm **KG** 59,61 Kg

**L** 2000 mm

Ref. 142 20 A C

**C** H 50 mm **KG** 63,87 Kg

Ref. 142 15 A D

**D** H 40 mm **KG** 55,64 Kg

Ref. 142 18 A D

**D** H 40 mm **KG** 61,26 Kg

Ref. 142 20 A D

**D** H 40 mm **KG** 66,11 Kg

## SERIE 150

**L** 1000- 1300- 1500-1800-2000

**L<sub>1</sub>** 810-1110- 1310- 1610- 1810

**H** 880

**C** **D** **M** e 50 mm

**e** 2 mm

Ref. 150 S

Base para armario serie 110.  
Support d'armoire série 110.  
110 series cabinet base.

Ref. 150 P

Pestaña superior.  
Onglet supérieur.  
Upper tab.

Bancos de trabajo configurables.  
Établis configurables.  
Customizable workbenches.



Pies ajustables en altura.  
Pieds réglables en hauteur  
Feet adjustable in height.



Cajones disponibles.  
Tiroirs disponibles.  
Available drawers.

**SERIE 129** **SERIE 113**  
**SERIE 132** **SERIE 153**  
**SERIE 133**



Montaje con tornillo (se entrega desmontado). Tornillos incluidos.  
Montage avec vis (livraison démonté). Vis inclus.  
Screw assembly (supplied disassembled). Included screws.

Gama de producto  
Gamme de produits  
Product range

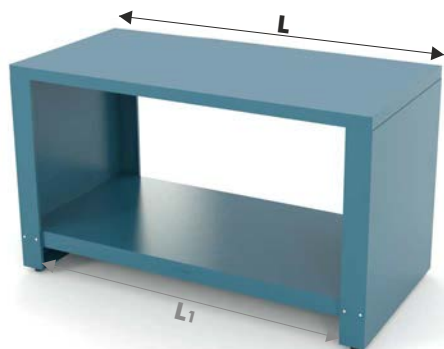

Ref. 150 A

L 1000 L1 810

Ref. 150 10 A   81 KgRef. 150 10 AD   82 KgRef. 150 10 AM   77 Kg

Ref. 150 P

L 1000 L1 810

Ref. 150 10 P   84 KgRef. 150 10 PD   85 KgRef. 150 10 PM   80 Kg

Ref. 150 S

L 1000 L1 810

Ref. 150 10 S   90 KgRef. 150 10 SD   97 KgRef. 150 10 SM   92 Kg

L 1300 L1 1110

Ref. 150 13 A   94 KgRef. 150 13 AD   94 KgRef. 150 13 AM   90 Kg

L 1300 L1 1110

Ref. 150 13 P   97 KgRef. 150 13 PD   97 KgRef. 150 13 PM   93 Kg

L 1300 L1 1110

Ref. 150 13 S   105 KgRef. 150 13 SD   111 KgRef. 150 13 SM   107 Kg

L 1500 L1 1310

Ref. 150 15 A   105 KgRef. 150 15 AD   103 KgRef. 150 15 AM   100 Kg

L 1500 L1 1310

Ref. 150 15 P   109 KgRef. 150 15 PD   107 KgRef. 150 15 PM   104 Kg

L 1500 L1 1310

Ref. 150 15 S   116 KgRef. 150 15 SD   121 KgRef. 150 15 SM   118 Kg

L 1800 L1 1610

Ref. 150 18 A   120 KgRef. 150 18 AD   117 KgRef. 150 18 AM   112 Kg

L 1800 L1 1610

Ref. 150 18 P   126 KgRef. 150 18 PD   120 KgRef. 150 18 PM   115 Kg

L 1800 L1 1610

Ref. 150 18 S   132 KgRef. 150 18 SD   137 KgRef. 150 18 SM   132 Kg

L 2000 L1 1810

Ref. 150 20 A   126 KgRef. 150 20 AD   129 KgRef. 150 20 AM   120 Kg

L 2000 L1 1810

Ref. 150 20 P   134 KgRef. 150 20 PD   134 KgRef. 150 20 PM   125 Kg

L 2000 L1 1810

Ref. 150 20 S   142 KgRef. 150 20 SD   151 KgRef. 150 20 SM   142 Kg

**SERIE 150 + 110**
**L** 1000- 1300- 1500-1800-2000

**L<sub>1</sub>** 810-1110- 1310- 1610- 1810

**H** 880 / 2030

 **e** 50 mm

 **2 / 1 mm**

 Encimeras.  
Plan de travail.  
Worktop.

 Conjunto banco de trabajo y armario con persiana.  
Ensemble établi et armoire à rideau.  
Workbench with shuttered cabinet.

 Armario mural con panel portaherramientas con persiana.  
Armoire murale avec panneau porte-outils avec rideau roulant.  
Wall-mounted cupboard with tool-holder panel with roller shutter.

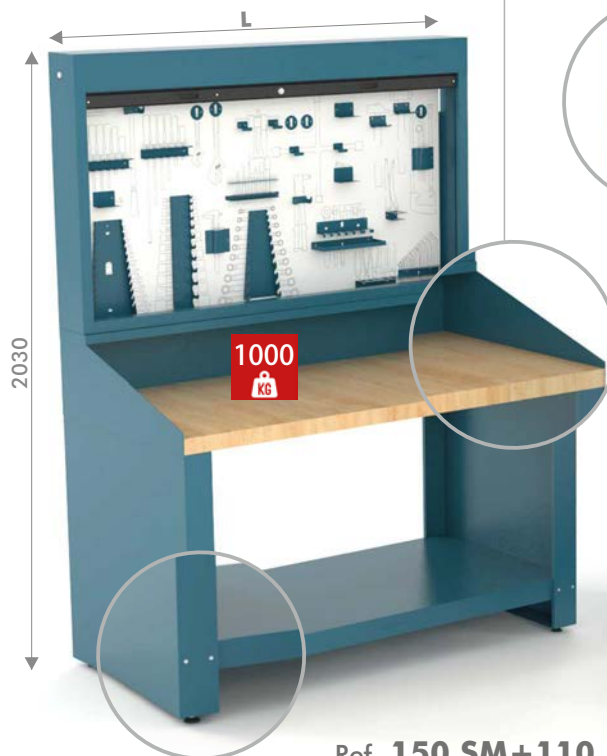
 **1 mm**

 Pies ajustables en altura.  
Pieds réglables en hauteur  
Feet adjustable in height.

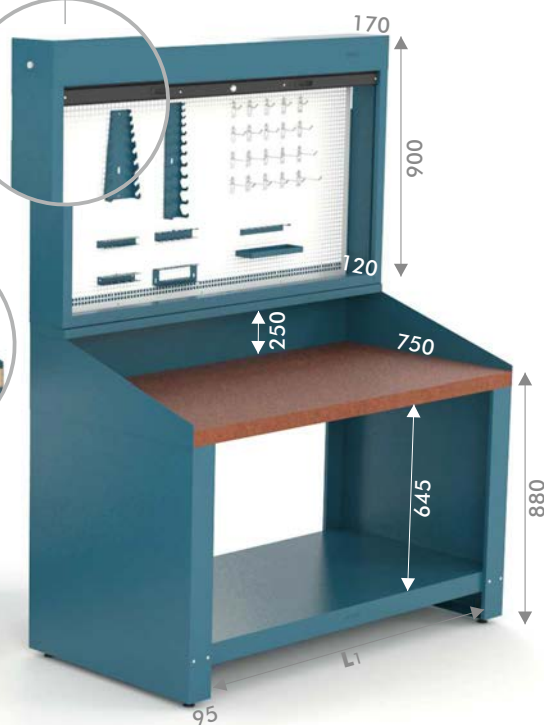
 **2 mm**
**Ref. 150 SM+110 1**

 Con panel serigrafiado.  
Avec panneau serigraphié.  
With screen printed panel.

**Ref. 150 SD+110 4**

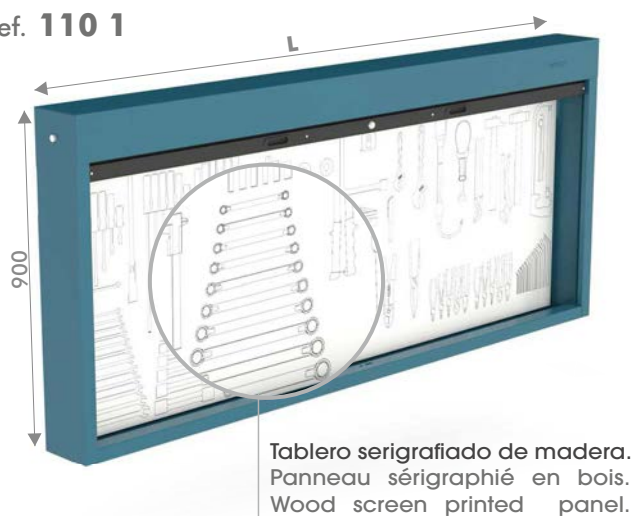
 Con panel perforado.  
Avec panneau perforé.  
With perforated panel.

 Montaje con tornillo (se entrega desmontado). Tornillos incluidos.  
Montage avec vis (livraison démonté). Vis inclus.  
Screw assembly (supplied disassembled). Included screws.

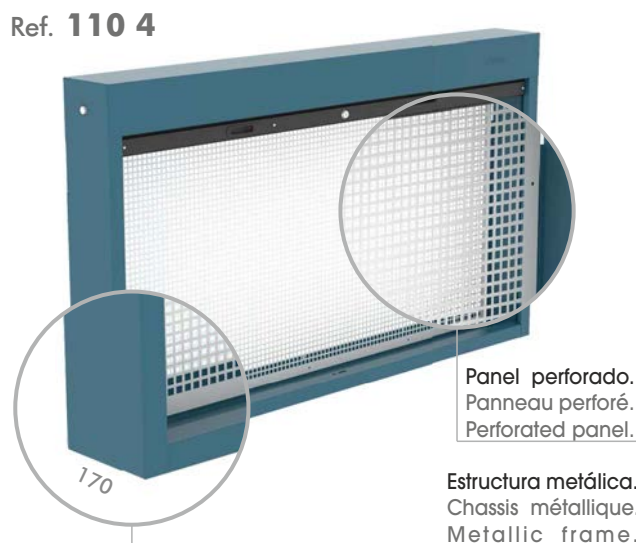
**Ref. 110 1**

 Tablero serigrafiado de madera.  
Panneau sérigraphié en bois.  
Wood screen printed panel.

**Ref. 110 4**

 Panel perforado.  
Panneau perforé.  
Perforated panel.

 Estructura metálica.  
Chassis métallique.  
Metallic frame.

 Con juego de tacos y tornillos.  
Avec jeu de chevilles et de vis.  
With set of plugs and screws.

 El armario no es apto para pladur sin taco especial.  
Ne convient pas pour mur en plâtre sans une cheville spéciale.  
Not suitable for plaster wall without a special wedge.

## SERIE 152

**L** 1000- 1500- 2000  
**L<sub>1</sub>** 810-1310- 1810  
**H** 900  
**e** 90 mm **e** 5 mm  
**e** 2 mm

Bancos de trabajo monobloque: totalmente soldado.  
 Établis monobloc: entièrement soudé.  
 Customizable fully-welded monoblock workbenches.

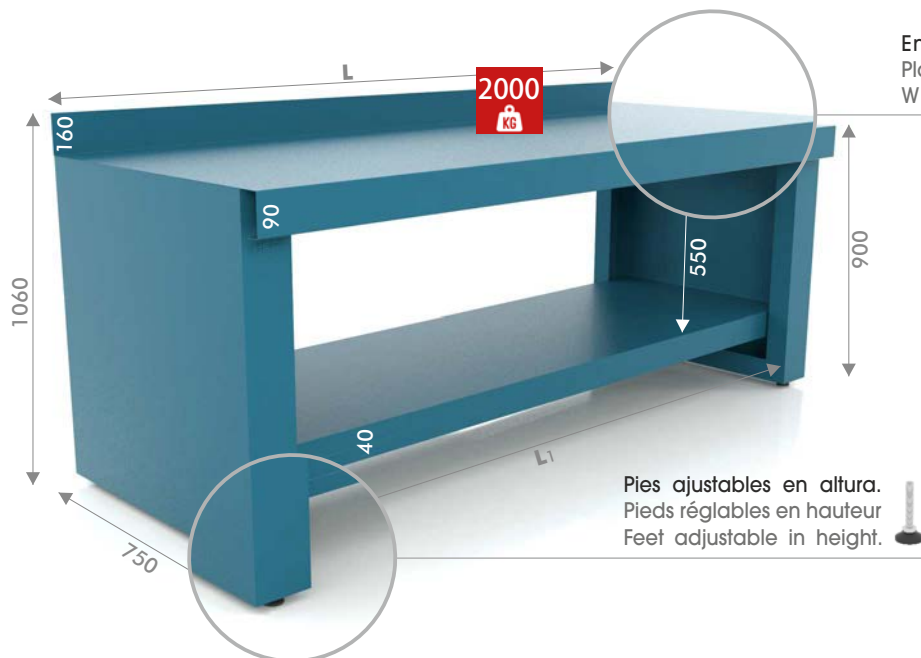

Encimera en una sola pieza.  
 Plan de travail en une seule pièce.  
 Worktop in one piece.

Pies ajustables en altura.  
 Pieds réglables en hauteur  
 Feet adjustable in height.

**i** Totalmente soldado.  
 Entièrement soudé.  
 Fully welded.

**i** Cajones disponibles.  
 Tiroirs disponibles.  
 Available drawers.

SERIE 129  
 SERIE 132  
 SERIE 133  
 SERIE 113  
 SERIE 153

Gama de producto  
 Gamme de produits  
 Product range

## Ref. 152 10

**KG** 82 Kg

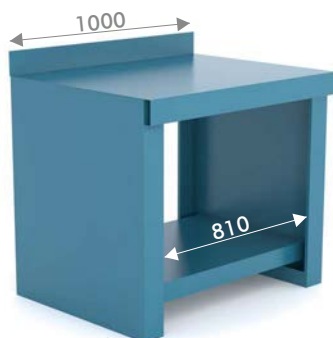

## Ref. 152 15

**KG** 110 Kg

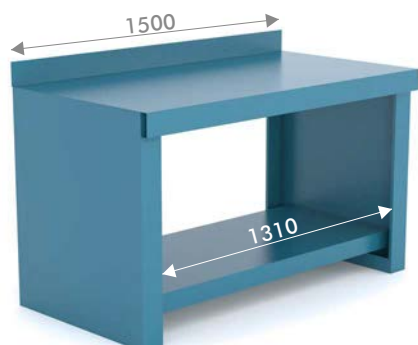

## Ref. 152 20

**KG** 138 Kg

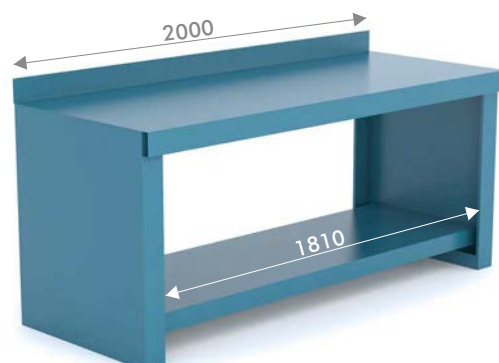

# CAJONES TIROIRS DRAWERS



Se sirven con tornillos para encimera metálica y de madera.  
Fourni avec des vis pour les plans de travail en métal et en bois.  
Supplied with screws for metal and wood worktops.

## SERIE 129

34,9 Kg

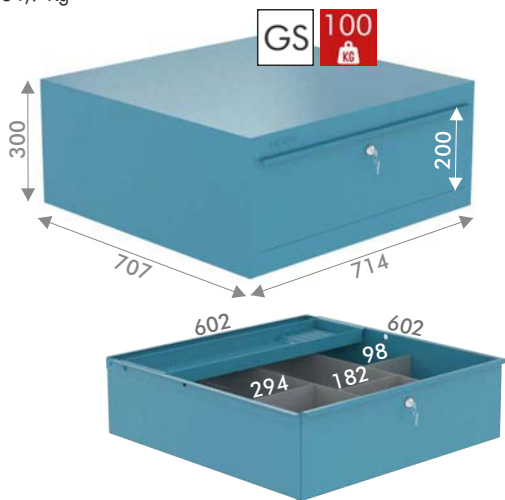

## SERIE 132

9 Kg

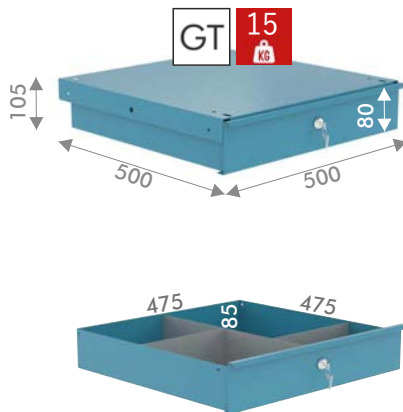

## SERIE 133

8 Kg

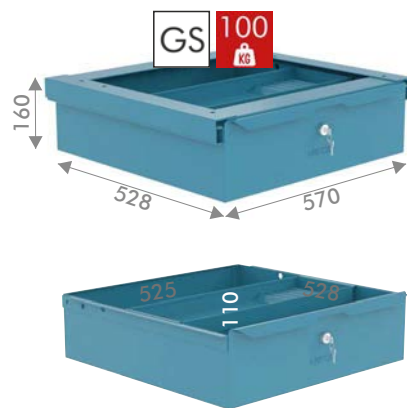

## SERIE 113

**GS 100**

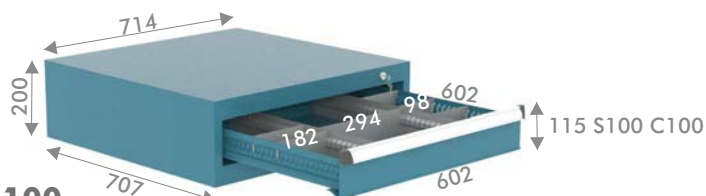

Ref. **113 1 100**

28 Kg

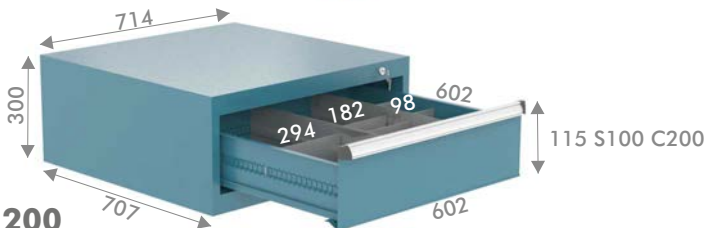

Ref. **113 1 200**

29 Kg

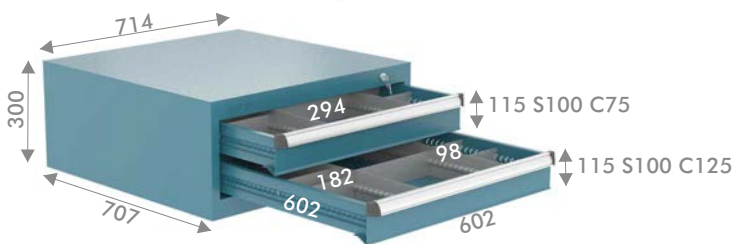

Ref. **113 2**

37 Kg

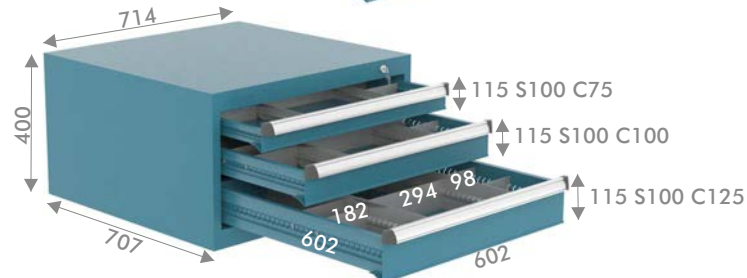

Ref. **113 3**

60 Kg

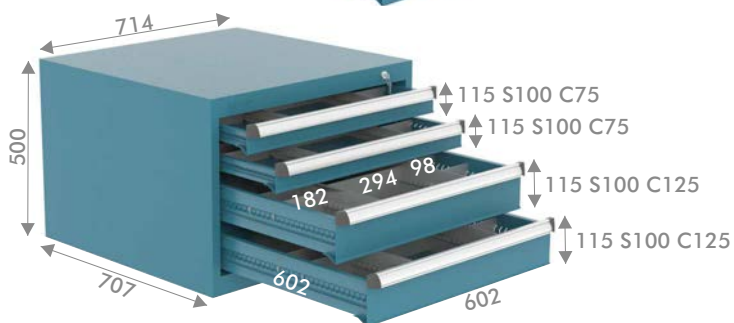

Ref. **113 4**

76 Kg

## SERIE 153

**GS 100**

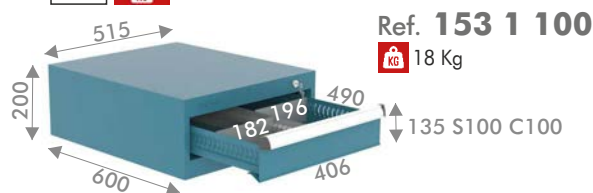

Ref. **153 1 100**

18 Kg

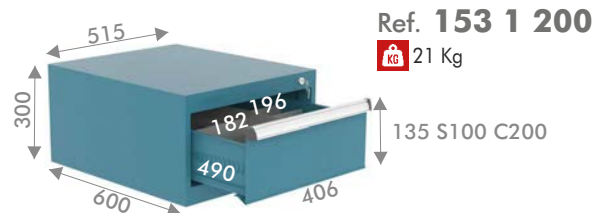

Ref. **153 1 200**

21 Kg

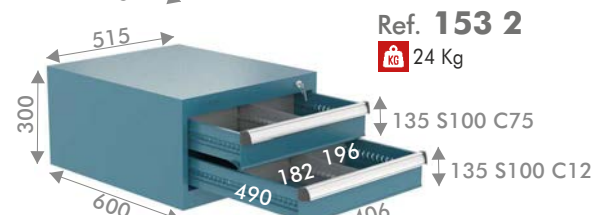

Ref. **153 2**

24 Kg

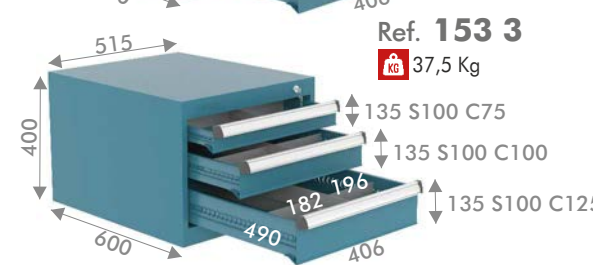

Ref. **153 3**

37,5 Kg

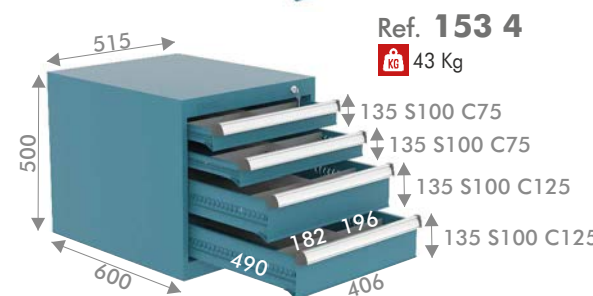

Ref. **153 4**

43 Kg

Regleta eléctrica para bancos de trabajo.  
Rampe d'alimentation pour établis.  
Power strip workbenches.

## REGLETA ELÉCTRICA RAMPE D'ALIMENTATION ELECTRICAL POWER STRIP

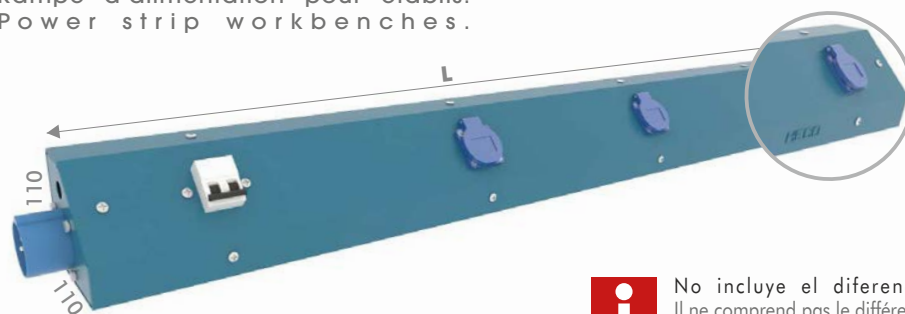

ESTRUCTURA  
CHÂSSIS  
FRAME  1 mm

 No incluye el diferencial (debe colocarlo el cliente fuera de la regleta).  
Il ne comprend pas le différentiel (celui-ci doit être placé par le client à l'extérieur de la multiprise).  
It does not include the differential (it must be placed by the customer outside the power strip).

 OPCIÓN: A medida (salida de aire, interruptores ... según necesidades específicas del cliente final).  
OPTION: Sur mesure (sortie d'air, interrupteurs ... en fonction des besoins spécifiques du client final).  
OPTION: Tailor-made (air outlet, switches ... according to specific needs of the end customer).

Gama de producto  
Gamme de produits  
Product range

Componentes en opción  
Composants en option  
Optional components



Ref. **112 RE 10**

 7 Kg  
 3u.



**L 1000**

Ref. **112 RE 13**

 8,5 Kg  
 4u.

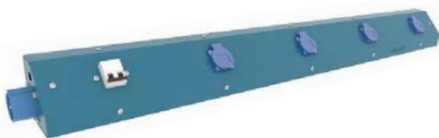

**L 1300**

Ref. **112 RE 15**

 9,5 Kg  
 5u.



**L 1500**

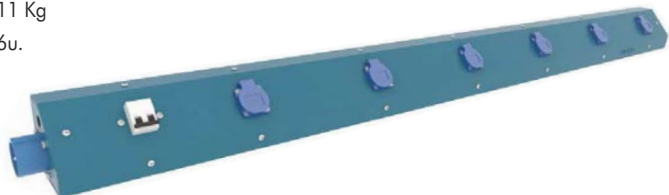

Ref. **112 RE 18**

 11 Kg  
 6u.



**L 1800**

Ref. **112 RE 20**

 12 Kg  
 7u.

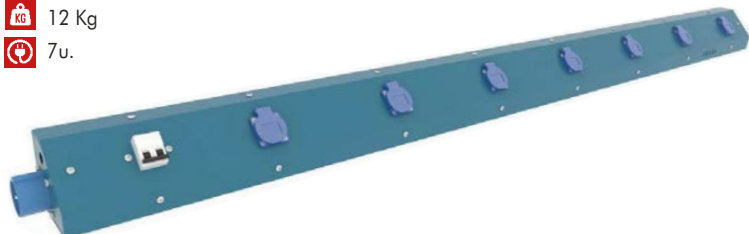

**L 2000**

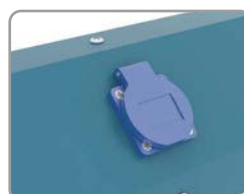

Toma de corriente 220 V  
Prise de courant 220 V  
220 V power outlet



Magnetotérmico 220 V  
Magnéto thermique 220 V  
220 V thermal magneto

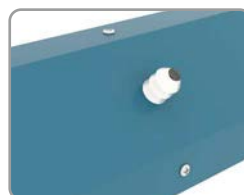

Toma de aire  
Prise d'air  
Air intake



Toma de Internet  
Prise d'Internet  
Internet power

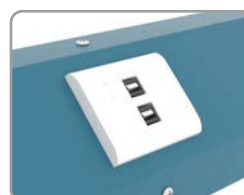

Toma de USB  
Prise USB  
USB socket

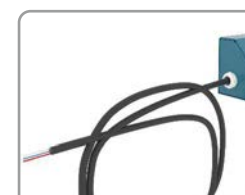

Cable de 2 metros  
Câble de 2 mètres  
2 meter cable

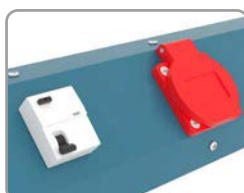

Toma de corriente 380 V  
Prise de courant 380 V  
380 V power outlet

Magnetotérmico 380 V  
Magnéto thermique 380 V  
380 V thermal magneto

 Para las regletas con elementos opcionales solicitar precio.  
Pour les multiprises avec des éléments optionnels, veuillez demander le prix.  
For power strips with optional elements, please ask for price.

# ENCIMERAS PLANS DE TRAVAIL WORKTOPS

Encimeras para bancos de trabajo.  
Plan de travail pour établis.  
Worktops for workbenches.

## Gama de producto estándar Gamme de produits standard Standard product range

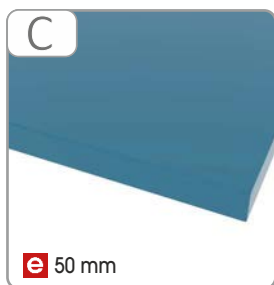

L Según referencia.  
Selon référence.  
According to reference. A 750 mm



### CHAPA TÔLE SHEET

Barras de refuerzo interior. Pintura anti-corrosión.  
Barres de renfort intérieures. Peinture anticorrosion.  
Inner reinforcement bars. Anti-corrosion paint.

SERIE 111/112/112 PM-PH/118/136/142/150/152





Ref. <b>112 E C 10</b>	 20,1 Kg
Ref. <b>112 E C 13</b>	 26,3 Kg
Ref. <b>112 E C 15</b>	 30,75 Kg
Ref. <b>112 E C 18</b>	 36,2 Kg
Ref. <b>112 E C 20</b>	 41,1 Kg



### DM MDF MDF

De densidad media. Protegido con barniz.  
Densité moyenne. Protégé avec du vernis.  
Medium density. Protected with varnish.

SERIE 111/112/112 PM-PH/118/120/136/142/150

Ref. <b>112 E DM 10</b>	 25,1 Kg
Ref. <b>112 E DM 13</b>	 20,65 Kg
Ref. <b>112 E DM 15</b>	 37,4 Kg
Ref. <b>112 E DM 18</b>	 44,9 Kg
Ref. <b>112 E DM 20</b>	 49,8 Kg



### CASTAÑO CHÂTAIGNER CHESTNUT

Elevada durabilidad y gran estabilidad. Barniz.  
Haute durabilité et stabilité. Vernis.  
High durability and great stability. Varnished.

SERIE 111/112/112 PM-PH/118/136/150

Ref. <b>112 E M 10</b>	 22,3 Kg
Ref. <b>112 E M 13</b>	 28,6 Kg
Ref. <b>112 E M 15</b>	 22,1 Kg
Ref. <b>112 E M 18</b>	 39,6 Kg
Ref. <b>112 E M 20</b>	 44 Kg



### GALVANIZADO GALVANISÉ GALVANIZED 1,5 mm

Dureza y resistencia. Protección electroquímica.  
Dureté et résistance. Protection électrochimique.  
Hardness and resistance. Electrochemical protection.

SERIE 120/121

CONSULTAR PRECIO Y PLAZO / CONSULTER LE PRIX ET LE DÉLAI / CHECK PRICE AND TERMS

## Gama de producto opcional Gamme de produits en option Optional product range

# ENCIMERAS PLANS DE TRAVAIL WORKTOPS

Gama de producto opcional  
Gamme de produits en option  
Optional product range



## ACERO INOXIDABLE ACIER INOXYDABLE STAINLESS STEEL **e** 1 mm

Su durabilidad permite una larga vida útil.  
Sa durabilité permet une longue durée de vie utile.  
Its durability allows a long useful life.

CONSULTAR PRECIO Y PLAZO / CONSULTER LE PRIX ET LE DÉLAI / CHECK PRICE AND TERMS

## RECUBRIMIENTO REVÊTEMENT COATING



PARA ENCIMERAS DM  
POUR PLANS DE TRAVAIL MDF  
FOR MDF WORKTOPS



## COMPACTO COMPACT COMPACT

CDF: Fibra de madera de alta densidad apto para aplicaciones en condiciones húmedas, revestido de melamina. Cumple las normativas EN22-5 y EN14322.  
CDF: Fibre de bois haute densité adaptée aux applications dans des conditions humides, revêtement mélaminé. Conforme aux normes EN22-5 et EN14322.  
CDF: High-density wood fibre suitable for applications in humid conditions, melamine coated. Complies with EN22-5 and EN14322.

CONSULTAR PRECIO Y PLAZO / CONSULTER LE PRIX ET LE DÉLAI / CHECK PRICE AND TERMS

Recubrimiento encimeras para bancos de trabajo, incluye protege cantos.  
Revêtement plan de travail pour établis, inclut une protection des bords.  
Coating worktops for workbenches includes edge protection.

L Según referencia.  
Selon référence.  
According to reference.

A 750 mm



**LISA**  
LISSE  
SMOOTH  
**KG** 40 Kg/cm<sup>2</sup>

Flexible, resistencia al envejecimiento y al frío.  
Flexible, résistance au vieillissement et au froid.  
Flexible, resistance to aging and to cold.

Ref. **112 10 GL**

Ref. **112 13 GL**

Ref. **112 15 GL**

Ref. **112 18 GL**

Ref. **112 20 GL**



**NBR** NITRILO  
NBR NITRILE  
NBR NITRILE  
**KG** 40 Kg/cm<sup>2</sup>

Para industria automovilística y aeronáutica. Propiedades antiestáticas.  
Pour l'industrie automobile et aéronautique. Propriétés antistatiques.  
For the automotive and aeronautical industries. Antistatic properties.

Ref. **112 10 GN**

Ref. **112 13 GN**

Ref. **112 15 GN**

Ref. **112 18 GN**

Ref. **112 20 GN**

# G O M A S CAOUTCHOUCS R U B B E R S